



**University of  
New Hampshire**

**ADEON Hardware Specification  
Version 2.3**

**Atlantic Deepwater Ecosystem Observatory Network  
(ADEON): An Integrated System for Long-Term Monitoring of  
Ecological and Human Factors on the Outer Continental  
Shelf**

**Contract: M16PC00003**

**Jennifer Miksis-Olds  
Lead PI**

**John Macri  
Program Manager**

**31 May 2018**

Approvals:

  
\_\_\_\_\_  
Jennifer Miksis-Olds (Lead PI)      31 May 2018  
Date

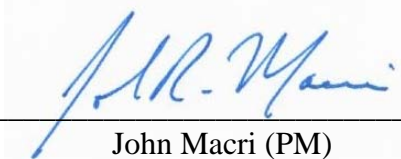
  
\_\_\_\_\_  
John Macri (PM)      31 May 2018  
Date



## Hardware Specification

---

Submitted to:  
ADEON  
*Contract: M16PC00003*

Authors:  
Bruce Martin  
Craig Hillis  
Jennifer Miksis-Olds  
Michael Ainslie  
Joseph Warren  
Kevin Heaney

12 July 2018

P001339  
Document 01412  
Version 2.3

JASCO Applied Sciences (Canada) Ltd  
Suite 202, 32 Troop Ave.  
Dartmouth, NS B3B 1Z1 Canada  
Tel: +1-902-405-3336  
Fax: +1-902-405-3337  
[www.jasco.com](http://www.jasco.com)



Suggested citation:

Martin B, C.A. Hillis, J. Miksis-Olds, M.A. Ainslie, J. Warren, and K.D. Heaney (2018). *Hardware Specification*. Document 01412, Version 2.3. Technical report by JASCO Applied Sciences for ADEON.

Disclaimer:

The results presented herein are relevant within the specific context described in this report. They could be misinterpreted if not considered in the light of all the information contained in this report. Accordingly, if information from this report is used in documents released to the public or to regulatory bodies, such documents must clearly cite the original report, which shall be made readily available to the recipients in integral and unedited form.

# Contents

1. INTRODUCTION .....	1
1.1. ADEON Project .....	1
1.2. Objectives .....	1
1.2.1. ADEON Project Objectives .....	1
1.2.2. ADEON Standardization Objectives .....	2
1.3. Report Structure and Terminology .....	2
2. ADEON HARDWARE .....	3
2.1. Selected Hardware Components .....	5
2.1.1. Bottom Lander sensors .....	5
2.1.2. Towed Array .....	8
2.1.3. Waterproof Fittings and Cable Connectors .....	14
2.2. Service Vessel Sensors .....	17
2.2.1. EK-60 and EK-80 Active Acoustics .....	17
2.2.2. Conductivity-Temperature-Depth .....	17
2.2.3. Net-tows .....	17
3. ADEON BOTTOM LANDER LOCATIONS AND DESIGN .....	18
3.1. Deployment Locations .....	18
3.2. ADEON Bottom Lander Design .....	20
4. PASSIVE ACOUSTIC DATA RECORDERS .....	23
4.1. Functional Blocks of Passive Acoustic Data Recorders .....	23
4.1.1. Hydrophones .....	24
4.1.2. Preamplifiers .....	24
4.1.3. Analog-to-Digital Converters and Anti-Aliasing Filters .....	25
4.1.4. Sample Clocks .....	26
4.1.5. Digital Sections .....	26
4.2. Hydrophone Mounting Relative to the Pressure Vessel .....	26
4.3. Designing Moorings to Minimize Self-Noise .....	27
4.4. Quantifying Recorder Performance .....	29
4.4.1. Signal Input & Hydrophone Testing .....	29
4.4.2. Data Analysis .....	30
4.4.3. Data Acquisition System Parameters .....	31
4.4.4. System-level Parameter - Crosstalk .....	31
4.5. System Performance .....	32
4.5.1. Maximizing Dynamic Range .....	32
4.5.2. Overload .....	32
4.5.3. Dominant Noise Source .....	32
5. ACTIVE ACOUSTIC RECORDERS .....	33
5.1. Remotely Deployed Echo Sounder Systems .....	34
5.1.1. Remote Deployment Hardware Limitations and Trade-offs .....	34
5.1.2. Selected Remote Deployed Echo Sounder System: Acoustic Zooplankton Fish Profiler (AZFP) .....	34

5.2. Vessel mounted echo sounder systems ..... 39

    5.2.1. Vessel-mounted Hardware Limitations and Trade-offs ..... 39

    5.2.2. ADEON Shipboard Acoustic Systems ..... 40

6. ACRONYMS ..... 41

LITERATURE CITED ..... 43

APPENDIX A. CALCULATING SOUND LEVELS FROM ACOUSTIC RECORDINGS .....A-1

APPENDIX B. SAMPLE SPECIFICATION SHEET FOR AUTONOMOUS RECORDERS.....B-1

APPENDIX C. SPECIFICATION SHEETS FOR EQUIPMENT..... C-1

## Figures

Figure 1. ADEON design including stationary bottom landers, mobile platforms, and remote sensing satellites for collecting data.....	3
Figure 2. The ADEON lander design showing the geometry of the tetrahedral array.....	6
Figure 3. (a) Bearing estimates of ship noise and detected impulsive sounds. (b) The empirical STBD of humpback whale low frequency sounds. ....	7
Figure 4. The OASIS Towed Array wrapped and coiled on the deck prior to deployment. ....	9
Figure 5. Sailboat array depth (ft) vs. tow speed (kn) .....	11
Figure 6. Spectrogram of the sound pressure level in a quiet beam at 4 and 8 knots .....	11
Figure 7. LP TARR stack. ....	15
Figure 8. LP TARR power conditioner.....	16
Figure 9. LP TARR power conditioner.....	16
Figure 10. ADEON bottom lander locations. ....	18
Figure 11. Histogram of ranges between all AMAPPS HARP and ADEON acoustic recorders.....	20
Figure 12. (Left) Sea surface currents in the project area on 18 Jul 2017 showing the Gulf Stream as purple-green-yellow and (right) distribution of daily mean current velocity.....	21
Figure 13. Acoustic propagation loss modeled for a 50–150 Hz source located at 10 m water depth above the Charleston Bump. ....	21
Figure 14. (Left) Bottom lander cut-away identifying the hardware components and (right) ADEON bottom lander .....	22
Figure 15. Block diagram of a passive acoustic data recorder. ....	23
Figure 16. Percentile spectra from two recorders deployed 10 m apart for 5 days in February 2013 in 50 m of water.....	27
Figure 17. Example (top) 1-minute decidecade SPL distributions and (bottom) percentile spectra that are dominated by flow noise. ....	28
Figure 18. Data from Figure 17 aligned to the start of low tide and averaged every 5 minutes for the 4 month recording.....	28
Figure 19. Generalized concept of a downward looking echo sounder.....	33
Figure 20. (Right) Two typical sub-surface bottom mooring deployment configurations.....	35
Figure 21. Example Certificate of Calibration provided for a 125 kHz transducer within the AZFP system.....	37
Figure 22. Illustration of a generic ping for a 4-channel AZFP and its associated timing.....	38
Figure 23. Illustration of burst interval sampling over a single deployment phase.....	39

## Tables

Table 1. ADEON sensor platforms, types, and sampling periods. ....	4
Table 2. Temporal and spatial resolutions of the selected ADEON remote sensing data.....	5
Table 3. Low Power Array Performance - Upgrade .....	10
Table 4. The wiring to the LP Towed Array.....	13
Table 5. ADEON bottom lander locations and water depths. ....	19
Table 6. Additional acoustic recording locations. ....	19
Table 7. AZFP acoustic characteristics given by transducer frequency .....	36
Table 8. Recorder metrics.....	B-1
Table 9. Standard hydrophone metrics. ....	B-2

# 1. Introduction

## 1.1. ADEON Project

The Atlantic Deepwater Ecosystem Observatory Network (ADEON) for the US Mid- and South Atlantic Outer Continental Shelf (OCS) has been developed and was deployed in fall 2017. The lead principal investigator (PI) for this project is Dr. Jennifer Miksis-Olds, University of New Hampshire (UNH). Dr. Miksis-Olds leads a collaborative research team consisting of individuals from UNH, OASIS, TNO, JASCO, Stony Brook University, and NOAA's Southwest Fisheries Science Center.

This observatory network will generate multi-year measurements of the natural and human factors active in this region, thus informing the ecology and soundscape of the OCS. Long-term observations of living marine resources and marine sound will assist federal agencies, including the Bureau of Ocean Energy Management (BOEM), the Office of Naval Research (ONR), and the National Oceanic and Atmospheric Administration (NOAA), in complying with mandates in the Endangered Species Act (ESA), Marine Mammal Protection Act (MMPA), and Sustainable Fisheries Act (SFA).

## 1.2. Objectives

### 1.2.1. ADEON Project Objectives

The ADEON project objectives are to:

- Establish an ecosystem observation network that provides baseline monitoring and supports predictive modeling of the soundscape and its relationship to marine life and the environment of the Mid- and South Atlantic Planning Areas.
- Develop standardized measurement and processing methods and visualization metrics for comparing ADEON observations with data from other monitoring networks.
- Assess baseline soundscape and ecosystem conditions in support of predictive environmental modeling and trend analyses in the planning areas.
  - How do soundscape and ecosystem components vary with water depth across the OCS?
  - How do the soundscape and ecosystem components vary with latitude along the OCS?
  - Where are the hot spots of human activity for consideration in ecosystem/habitat health impacts?
- Assess the spatial and temporal distribution of the soundscape and biological scatterers, including their expected variation and correlation with distance from the lander locations.
  - What are the environmental factors that define and constrain the horizontal range of appropriate extrapolation of observations measured at the stationary lander sites?
- Develop and apply new methods for the effective visualization of five-dimensional (5-D—time, latitude, longitude, frequency, and depth) soundscape data with interactive visual analysis tools that enable users to explore, analyze, and integrate ancillary ecosystem data streams with the 5-D soundscape.
- Develop a robust data management system that archives and provides public access to multiple data streams to encourage future development of ecological models targeted at questions beyond the scope of this study.

## 1.2.2. ADEON Standardization Objectives

The objectives of ADEON's Standardization task are to:

- Ensure compatibility within ADEON between soundscapes based on measurements and those based on models;
- Ensure compatibility between measurements made by different researchers and institutes within ADEON;
- Facilitate compatibility between ADEON soundscapes, whether based on measurement or model prediction, and soundscapes produced by a hypothetical future or parallel project within the US Exclusive Economic Zone (EEZ);
- Facilitate compatibility between metrics used to quantify ADEON soundscapes and those used to monitor ambient sound in the context of the EU's Marine Strategy Framework Directive (MSFD).

## 1.3. Report Structure and Terminology

This document describes the ADEON hardware and how its performance is measured. The Calibration, Deployment and Good Practice Guide (Warren et al. 2018b) contains details of how the equipment was configured for ADEON data collection. In this document, Section 2 provides an overview of the hardware selected. Section 4 describes the generic structure of autonomous acoustic recorders along with performance issues associated with trade-offs in selecting different types of components. Quantitative and qualitative metrics for assessing the performance of recorders are described in Section 4.4. Section 5 describes active acoustic echo sounders for biologic measurements. Acronyms are listed in Section 6.

The main report is followed by:

- Appendix A. Calculating Sound Levels from Acoustic Recordings.
- Appendix B. Sample Specification Sheet for Autonomous Recorders.
- Appendix C. Specification Sheets for Equipment.

The word “shall” is used throughout this document to mean “shall at a minimum”, indicating a requirement for compliance with this standard. Similarly, the word “should” means “should if possible”, indicating a recommendation, not required for compliance with this standard.



## 2. ADEON Hardware

The ADEON program selected a range of hardware components to generate a time-series of acoustic data and supporting data that address the project objectives (Section 1.2.1). Conceptually, the ADEON network consists of stationary bottom landers, towed array missions using sailboats, and vessel-based measurements supplemented with space-based remote sensing (Figure 1). It also leverages data from established ocean observation systems and databases (Figure 1 and Table 1).

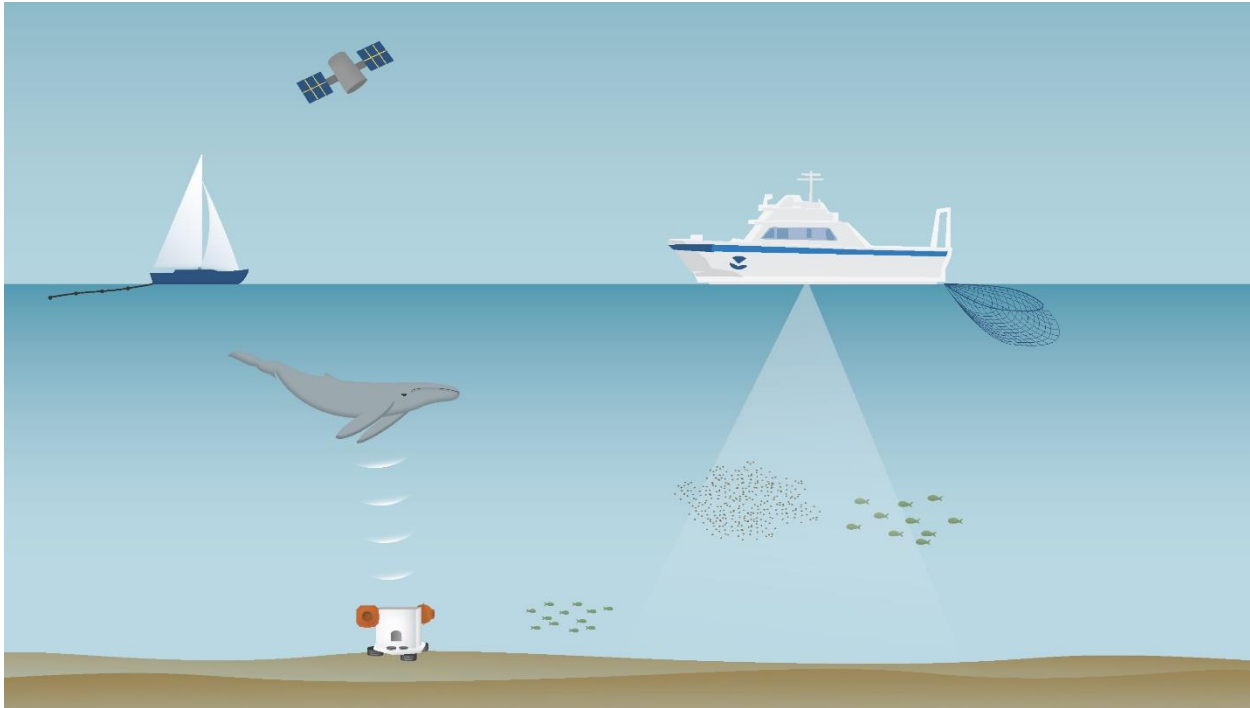

Figure 1. ADEON design including stationary bottom landers, mobile platforms, and remote sensing satellites for collecting data.

The seven stationary bottom landers provide a continuous time-series of passive acoustic data, active acoustic backscatter measurements of the prey field, hydrographic measurements of the local physical environment, and detections of passing tagged fish. Two types of bottom landers were deployed: three bottom landers with both AZFP echo sounders and VEMCO receivers (fish tag loggers); and four bottom landers with neither. The passive acoustic data from the ADEON bottom landers complement measurements performed by the Duke/USN [Living Marine Resources Program](#) being conducted until mid-2020, NOAA's [AMAPPS](#) program through summer 2019, and the long-term NOAA [Noise Reference Station](#) program.

The time-series measurements from the bottom landers were supplemented with targeted measurements from a towed array support vessel, the bottom lander service vessel, and remote sensing (Table 1). During the bottom lander service cruise, the service vessel:

- Made detailed water column measurements with conductivity, temperature and depth (CTD) loggers and active sonar transects,
- Conducted net tows to sample the zooplankton community structure, and
- Had visual observers document the presence of marine life including sunfish, turtles, sharks, birds, and marine mammals.

Separate towed array cruises deployed a horizontal line array (HLA) with 32 hydrophone channels spaced for effective beamforming at 800 Hz, which provided bearing-time-response (BTR) curves of the ambient sound field. The arrays estimated ambient noise directionality from 50 Hz to 1 kHz, albeit with poor bearing resolution at the lower frequencies. The tow vessel also regularly collected CTD measurements.

Table 1. ADEON sensor platforms, types, and sampling periods.

Platform	Sampling protocol	Omni acoustics	Directional acoustics	Horizontal line array	Active acoustics	CTD/SST	Chlorophyll a	Dissolved oxygen	Fish tracking	Visual observations	Vessel tracking	Wind, wave, and surface features
Standard bottom landers (4)	Continuous on duty cycle	✓	✓			✓		✓				
Active acoustic bottom landers (3)	Continuous on duty cycle	✓	✓		✓	✓		✓	✓			
Towed array	During cruises	✓	✓	✓		✓						
Vessel measurements	Continuous: Active acoustics, SST, and Chl a Station sample: CTD, net tow Day hours: Visual observations				✓	✓	✓	✓		✓		
Remote sensing	As available					✓	✓				✓	✓
Accessible databases	As available					✓					✓	✓

Space-based remote sensing is an excellent resource that provided a continuous data set of chlorophyll-a concentration; net primary productivity (NPP); sea surface temperature (SST); wind and wave fields; large vessel traffic (S-AIS); and fishing traffic (VMS). Table 2 lists the data sources and resolutions of the satellite data. These data were supplemented with accessible databases, such as the Argo program (which measures oxygen, carbon dioxide, and pH), Global Real-Time Ocean Forecast system (RTOFS) program, and the Pioneer Coastal Ocean Observatory north of the project area. The satellite data were also supplemented by data from oceanographic buoys within the project area, specifically buoys NDBC41010, NDBC41002, NDBC41004, NDBC41025, and NDBC44014 (see Figure 10).

Table 2. Temporal and spatial resolutions of the selected ADEON remote sensing data

Parameter	Data source	Spatial resolution	Temporal resolution
Chlorophyll-A (CHL-a)	NASA VIIRS	4 km	8-day composite
Sea surface temperature (SST)	NASA Modis-Aqua	4 km	8-day composite
Net primary productivity (NPP)	Oregon State (VGPM model)	12 km	8-day
Mixed layer depth (MLD)	Oregon State (Hycom model)	12 km	8-day
Wind speed and direction	IFREMER (France)	1/4 degree	Daily
Ocean currents (includes geostrophic components)	GlobCurrent (France)	1/4 degree	Daily
Ocean currents (including wind driven component)	GlobCurrent (France)	1/4 degree	6-hour

## 2.1. Selected Hardware Components

### 2.1.1. Bottom Lander sensors

#### 2.1.1.1. Omni-directional and Directional Passive Acoustics

The passive acoustic recordings were made by Autonomous Multichannel Acoustic Recorders (AMARs; JASCO Applied Sciences). The AMAR is a well-tested, high-performance recorder that exceeds the minimum recorder specifications described in Section 4 and Appendix B. The AMAR was equipped with M36-V35-100 omnidirectional hydrophones and M20-601 directional sensors (accelerometers) from GeoSpectrum Technologies. The equipment was extensively trialed on the ADEON bottom lander prior to the ADEON deployment.

Of the seven AMARs deployed in Fall 2017, one was equipped with the M20 accelerometer, and the other six with a tetrahedral array comprising four M36 hydrophones (Figure 2). The accelerometer has a frequency range of 1 Hz to 3 kHz. The bearing resolution specified by the manufacturer (GeoSpectrum Technologies Inc.) is 2°. The resolution decreases (i.e., the angular uncertainty increases) with decreasing frequency and decreasing signal to noise ratio.

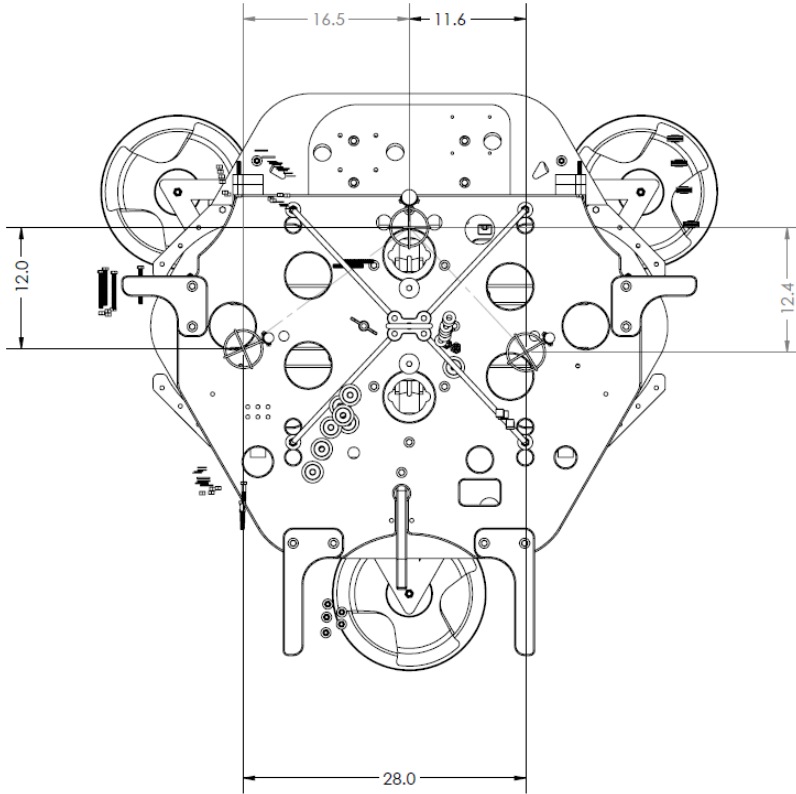

Figure 2. The ADEON lander design showing the geometry of the tetrahedral array (plan view).

Each side of the tetrahedron is an equilateral triangle whose sides have length 58.9 cm (23.2 in). An example illustrating the angular resolution of a larger tetrahedral array (185 cm spacing) is shown in Figure 3, showing the short-time bearing distribution (STBD, the angular equivalent of a spectrogram) of humpback whale sounds (middle panel). In general the bearing resolution of the tetrahedral array depends on frequency and bandwidth of sounds of interest.

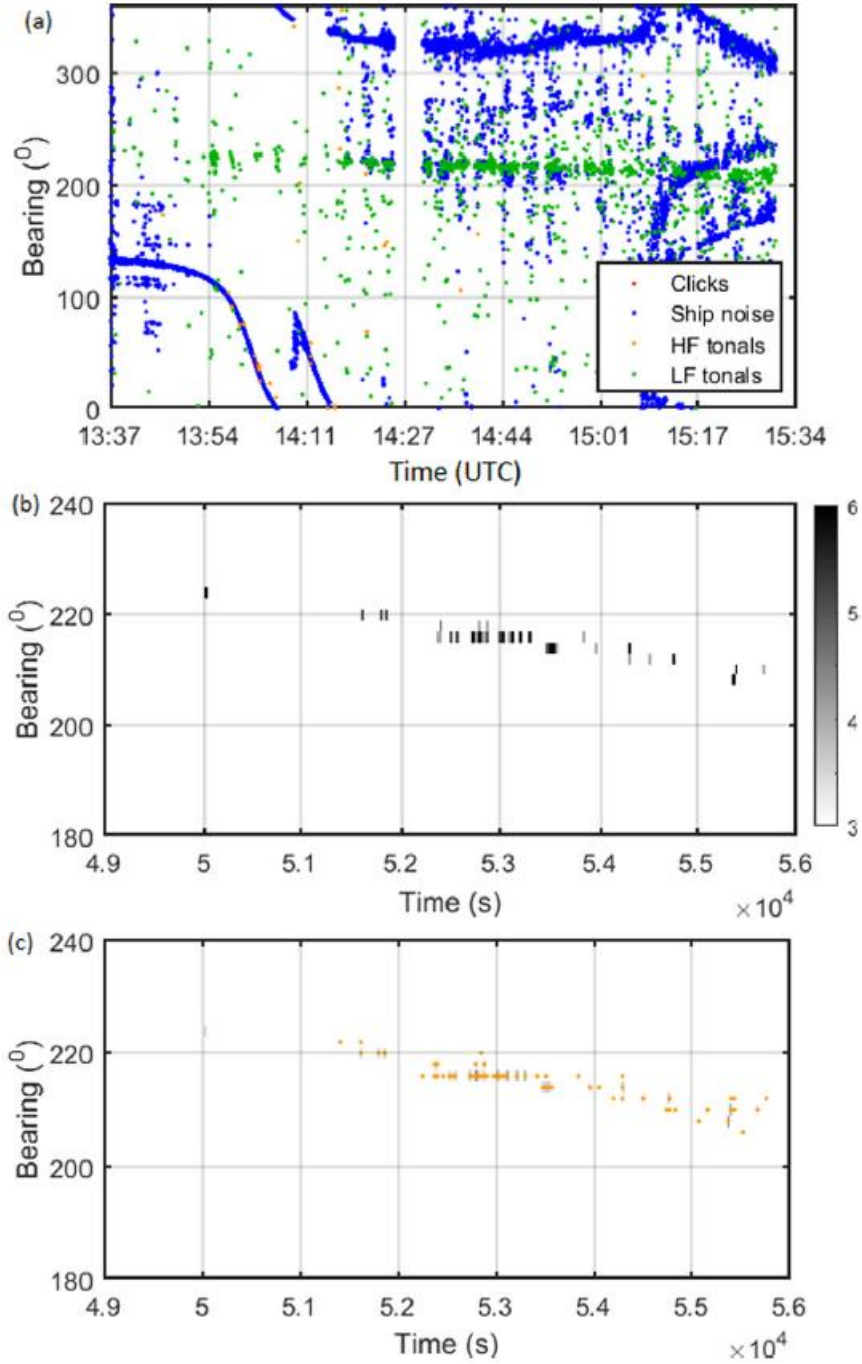

Figure 3. (a) Bearing estimates of ship noise and detected impulsive sounds. (b) The empirical STBD of humpback whale low frequency sounds. The gray scale indicates the number of bearing estimates in each time and bearing bin. (c) Automatically created cluster of humpback whale bearings. Reproduced from Urazghildiiev and Hannay (2018).

### 2.1.1.2. Active Acoustics–Acoustic Zooplankton and Fish Profiler (AZFP)

The AZFP from ASL Environmental Sciences collected the active acoustic data for ADEON on the bottom landers. These recorders are described in Section 5. They were selected because they are well-known within the scientific community (and our team) to be reliable for remote data collection and calibrations.

### 2.1.1.3. Conductivity-Temperature-Dissolved Oxygen

The Sea-Bird MicroCAT SBE-37 CT-DO logger was chosen to measure conductivity, temperature, and dissolved oxygen because of its accuracy, reliability, and ease of integration. The MicroCAT family is a world standard for CT logger instruments, with very well-established accuracy and precision. Sea-Bird has produced more than 10,000 instruments in this family, so the reliability is also well-proven. A dissolved oxygen sensor is a standard option, which allowed us to record several important parameters with one instrument and without extra engineering effort at the bottom lander design phase.

There are two types of dissolved oxygen sensors: electrode and optical designs. The conventional sensor is the electrode design, in which oxygen diffuses through a membrane into an electrolyte and reacts with an electrode. The measured current is proportional to the oxygen concentration. This type of sensor is sensitive to biological and non-biological fouling, particularly in moored applications. In contrast, the optical sensor design is more resistant to fouling, as it does not depend on the sensitive membrane and electrolyte.

The selected MicroCAT logger has an integrated optical DO sensor, with the additional benefit of the pumped CT path helping to further minimize the risk of sensor fouling. Appendix C.1 provides details of the SBE-37.

### 2.1.1.4. Fish-tag Loggers

The VEMCO VR-2W fish-tag loggers were deployed on the bottom lander. They were selected due to their low cost and the large number of fish tagged with the VEMCO 69 kHz tags. Appendix C.2 provides specifications of the loggers.

## 2.1.2. Towed Array

### 2.1.2.1. Sailboat Cruise Objectives

To address the fourth program objective of determining the spatial and temporal distribution of the soundscape, a set of four sailboat cruises with a towed horizontal line array (HLA) are planned. The proposed list of sites to visit for the four cruises are listed below:

- Cruise 1: VAC to HAT
- Cruise 2: HAT to WIL
- Cruise 3: WIL to CHB
- Cruise 4: CHB to JAX

For each cruise, weather permitting, a transect from one lander to the adjacent lander and back will be performed. The first cruise, scheduled for early June 2018, will visit the two landers closest to shore, VAC and HAT, which are ~60 nmi from shore. Once we complete one test, the feasibility using a small sailboat to visit the other sites farther off shore will be examined.

The mobile towed array will provide noise directionality and the spatial distribution of the noise. The test plan will involve deploying a short (~10–20 m) horizontal line array at one lander position and then sailing to the next nearest lander. After recovering the landers, the passive acoustic data from each lander can be correlated with the sailboat HLA data to estimate the spatial and temporal decorrelation length/time.

The deliverable for each sailboat cruise is a cruise test plan, a post-cruise report, and the binary data in post-processed form. The raw data will be provided to UNH for archiving. The incoherent band averaged (across each ADEON decidecade band) bearing-time-record (BTR) will be provided for public distribution. Metadata will include cruise logs and ship navigation data.

### *2.1.2.2. Hardware Specifications*

#### *2.1.2.2.1. Array Specifications*

The recording array will be the OASIS Towed Array 3 (OTA3) (Figure 4), which has been deployed from a sailboat off Oahu, HI to obtain passive recordings of humpback whales. Table 3 lists the array parameters.



Figure 4. The OASIS Towed Array wrapped and coiled on the deck prior to deployment.



Table 3. Low Power Array Performance - Upgrade

Parameter	OASIS Towed Array 3
Design frequency	1000 Hz
No. of channels	16
No. of hydrophones per channel	2
No. of non-acoustic sensors	2 (fwd + aft, in chan 1 and 18) do not work
Bit depth	16
Digitization rate	3125 Hz fixed
Preamplifier voltage gain ( <i>G</i> )	1, 2, 4, 8 V/V (via switch, corresponding to level gain of 0, 6, 12, 18 dB)
ADC sensitivity to voltage	7.28 mV <sup>-1</sup> (corresponding to 4.5 volts per 32768 digital counts)
Hydrophone free-field sensitivity to voltage	26.6 mV/Pa (corresponding to a sensitivity level of -151.5 dB re 1 V <sup>2</sup> /∞Pa <sup>2</sup> )
Noise floor (maximum gain)	specified by the manufacturer as "SS0-10dB (caution, very sensitive to electronic noise, 60 Hz) (Anti alias only 85 dB)"
Acoustic aperture	12 m
Array leader	10 m
Array diameter	27.9 mm (1.1 in)
Leader diameter	15.88 mm (0.625 in)
Buoyancy	Roughly neutral to start, now slightly negative due to gel loss
Fill material	Gel
Storage media (raw data)	CF cards
Direct current supply voltage	12 V
Power	2 watts (includes TARR)
Data interface	Ethernet-Realtime to DSP Ethernet-Data Upload to PC RS232-Param Settings (using set command) and Error/Log Messages
TA/TARR connectors	SMA and screw terminals
Status errors	host status of 0x7000 (with CF card) or 0xF000 (no card) indicate normal ops. Typical error might be 0x8000.
TARR form factor	PC-104

The array was deployed and tested as part of the KauaiEx 2010 experiment. A significant study of array depth and flow noise as a function of sailboat speed was conducted. Figure 5 shows the results of the cable depth, compared with a model developed for scope vs. speed.



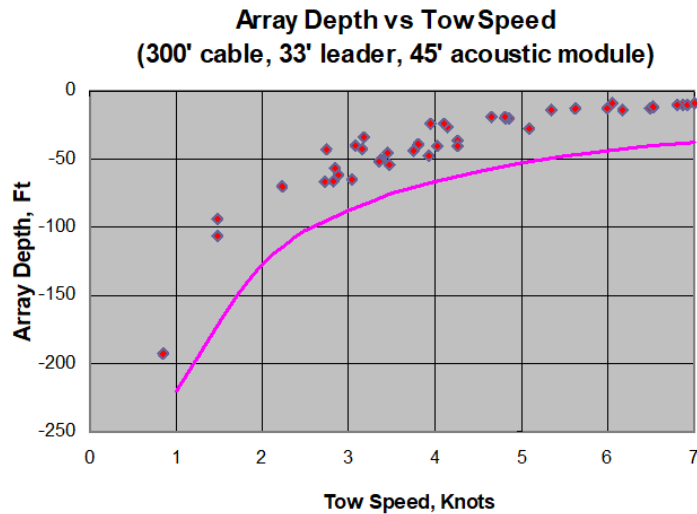

Figure 5. Sailboat array depth (ft) vs. tow speed (kn): model prediction (magenta line) and measured array depth (red diamonds). Cable length is 91 m (300 ft), leader is 10 m (33 ft), and acoustic module is 14 m (45 ft).

The science objective of the ADEON sailboat cruise will be well met with the array between 9.1 m (30 ft) and 15.2 m (50 ft) long, which is indicated above by tow speeds between 2 and 4 knots (1–2 m/s). The ambient noise recordings (Figure 6), also demonstrate the requirement that the sailboat be kept at a speed of 4 knots (2 m/s) or less. This requirement depends on the local weather conditions, the wind and the sea-surface currents, and the fact that ship safety supersedes science goals.

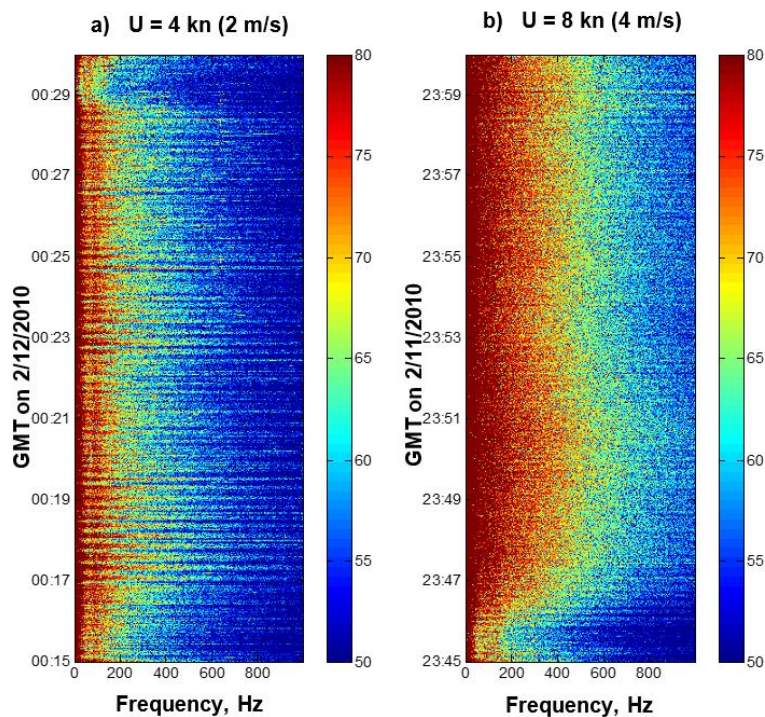

Figure 6. Spectrogram of the sound pressure level in a quiet beam at 4 and 8 knots (2 and 4 m/s) (30° Forward of Broadside) dB re 1  $\mu\text{Pa}^2$ .

### 2.1.2.2. Towed Array Receiver/Recorder

The Low Power Array Towed Array Receiver/Recorder (LPA TARR) is a dual-port Ethernet switch designed to transport data from a Compact Towed Array (CTA) based telemetry to a processing unit. Additionally, the TARR has the capability to record the telemetry data to CompactFlash removable media and is configurable via a serial port or Telnet. The recorded telemetry data can be recovered by removing the media or through using an embedded File Transfer Protocol (FTP) server.

### 2.1.2.3. Connections

Figures 7 and 8 show the TARR Board Schematic. This board accommodates the LP TARR and New HP TARR. All components for both configurations are shown in Figure 7.

The TARR external Communication connections (identified on the board as J- numbers) are as follows:

1. Two RJ-45 10/100 Ethernet ports (J8). Either or both ports can be used to receive array data as well as send commands and communicate with the TARR. Both ports are connected to an on-board MAC/PHY with built-in switching capabilities and MAC addressing. Therefore, if the array data is being transmit to a MAC on port 1, the data will not be transmitted to port 2.
2. Two 3-PIN RS-232 serial ports (J1 & J3).
  - One port (J1, the farthest from the RJ-45 ports) communicates to the TARR serial interface and can directly command the unit, set configurable parameters, and get status and information (including file information) regarding the CompactFlash media. This port operates at 19200/8/N/1/N over VT100.
  - The second of the serial ports (J3, the closest to the RJ-45) is configured for 4800/8/N/1/N over VT100 and listens for incoming NMEA0183 GPS data. This port will receive and record (when available) two NMEA strings, "DPT" and "HDG." A third NMEA string, "ZDA," will update the TARR's on-board real-time clock (RTC) chip with the received UTC date and time. This clock update will only occur for the first ZDA string received after each power-on or wake, after which time subsequent ZDA strings will be discarded.
3. One SMA array data port (J7). This port connects to the uplink data path from the Low Power Array. (note that the board has been designed to accommodate a second SMA port in the future, J6, which is shown in Figure 1).
4. One USB port (J2). Currently not configured to work.

Six connections are needed for communicating with the LP TA. These connections consist of one coaxial cable and two pair of power leads. Table 4 lists the wiring.

Table 4. The wiring to the LP Towed Array.

Pin numbers for all connectors	Wire	TARR Terminal
1	COAX +	SMA-J7
2	COAX - (shield)	"
3	N/A	
4	N/A	
5	N/A	
6	N/A	
7	Power AM +	ST3
8	Power, NAS +	ST5
9	Power, AM - (common)	ST4
10	Power, NAS - (common)	ST6

#### 2.1.2.4. Configuration

The TARR can be configured using the serial or telnet ports for the following parameters:

- TARR.SRCIP: Source IP address of the TARR unit (applies to all outgoing packets)
- TARR.DSTIP: Destination IP address of the array data packets
- TARR.FILESIZE: Size of each array data file stored on the removable media.
- TARR.SRCUDP: Source UDP port of the array data packets
- TARR.DSTUDP: Destination UDP port of the array data packets
- TARR.NASON: NAS sensor power turn-on time in hundredths of seconds (100 = 1 second)
- TARR.NASOFF: NAS sensor power turn-on time in hundredths of seconds (1500 = 15 seconds)

These parameters can be configured using the “set” command via the serial port or telnet session. After any parameter is set, the array data packets (if enabled) will be updated with the appropriate information.

To set a parameter via the set command, the user should type “set <variable> = <value>” from the prompt. The variables are not case sensitive, spaces before and after the equal sign are optional, and values must be entered in decimal. For the IP addresses, the format of the value includes decimal point breaks (e.g., “set TARR.SRCIP = 192.168.0.144”).

To see the current value of the set variables, type “set” without any additional parameters from the prompt. Additional variables may be displayed at the prompt than those listed above (in support of legacy applications), but parameters not listed above are deprecated and cannot be changed.

If recording is disabled via the serial or telnet ports for any reason, or the user would like to perform a soft reset, the command “reboot” can be used to cycle power on the TARR remotely.

### 2.1.2.5. Date/Time

The date and time stored in the RTC can be accessed and modified using the “date” or “time” commands from the serial port or via telnet. Both commands perform the same function and can be used interchangeably. This manual uses “date” in examples.

To read the current date and time, type “date” from the prompt.

To set the date and time, type “date MM-DD-YYYY HH:MM:SS” from the prompt. The month, day, hour, minute, and second fields must be padded to two characters and only four digit years are accepted. When setting the date/time in this manner, the tenths and hundredths of seconds are reset to zero.

After setting the date and time, they are displayed back to the user. Depending on the latency in setting and reading the time, the tenths and hundredths of seconds may be greater than zero, since the clock is running.

The system makes no reference to time zones, so it is up to the user to enter either local time or a fixed reference such as Greenwich Mean Time (GMT).

### 2.1.2.6. Media Access

The removable media, when present, will contain array data files in the format XXXXXXXX.dat where XXXXXXXX contains the current UTC time in hexadecimal. These files are referred to as DAT files, and their format is not addressed in this document. Additionally, a single error log file (logfile.txt) contains logged information regarding array health or other pertinent information that the user may be interested in.

Before performing any media commands, recording should be disabled by typing “dr” (for disable recording) at the serial or telnet prompts. This ensures that any open files on the media are closed and can be accessed. Media commands listed here are only available from the serial port and cannot be accessed via telnet.

To format the removable media, type “format” from the prompt. The user will be warned that all data on the drive will be deleted and must type “Y” at the prompt to continue. Any other user input will abort the format process. The commands are not case sensitive.

To retrieve the directory listing of the media, type “dir” from the prompt.

To delete a file from the media, type “del <filename>” from the prompt. Multiple files can be deleted by using wildcards “\*” and “?” in the same manner as in dos systems. (e.g., del \*.\* , del 4\*.dat, and del 4?56A834.\*). No additional wildcards are supported.

## 2.1.3. Waterproof Fittings and Cable Connectors

The fitting on the end of LP TARR is an Impulse Titan MKS(W) 3L10-CCP-UT. The Glider Bulkhead fitting is an Impulse 12 pin female 90° LPBH-12-MP. The adaptor cable for the Glider will therefore need an Impulse Titan Bulkhead MKS(W) 3L10-BCR mated to an Impulse 12 pin LPIL-12-MP. (All connectors should be wired “straight through”. i.e., 1 to 1, 2 to 2...10 to 10. The mating Bulkhead connector for the LPTA (OTA3) is an Impulse Titan MKS(W) 3L10-BCR (used in the adaptor cable and for benchtop testing).

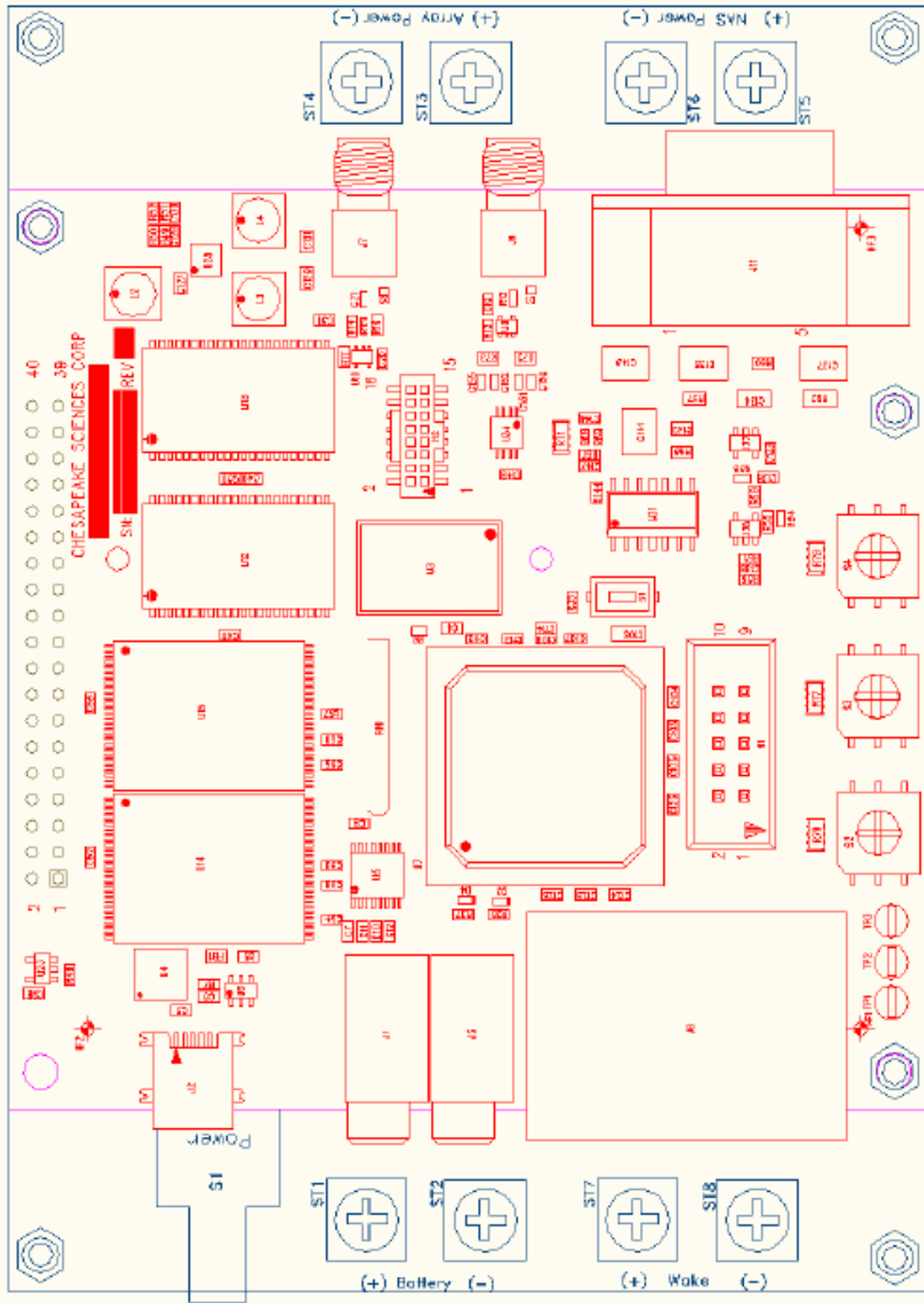

Figure 7. LP TARR stack.

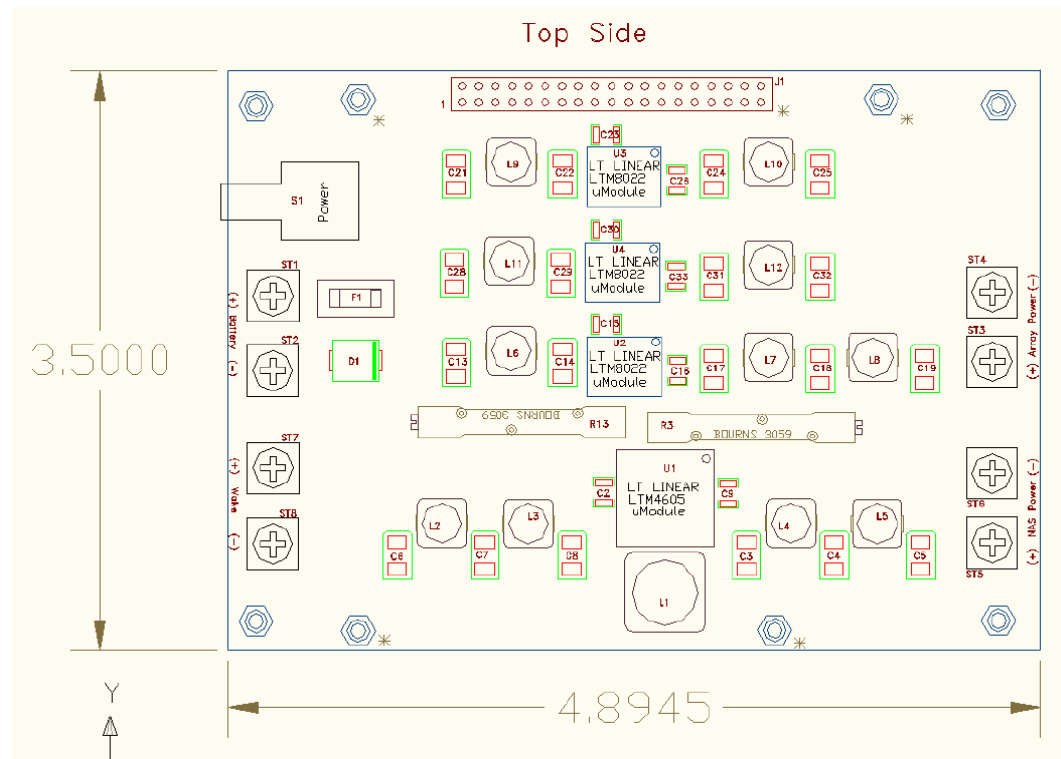

Figure 8. LP TARR power conditioner (bottom board): Top view

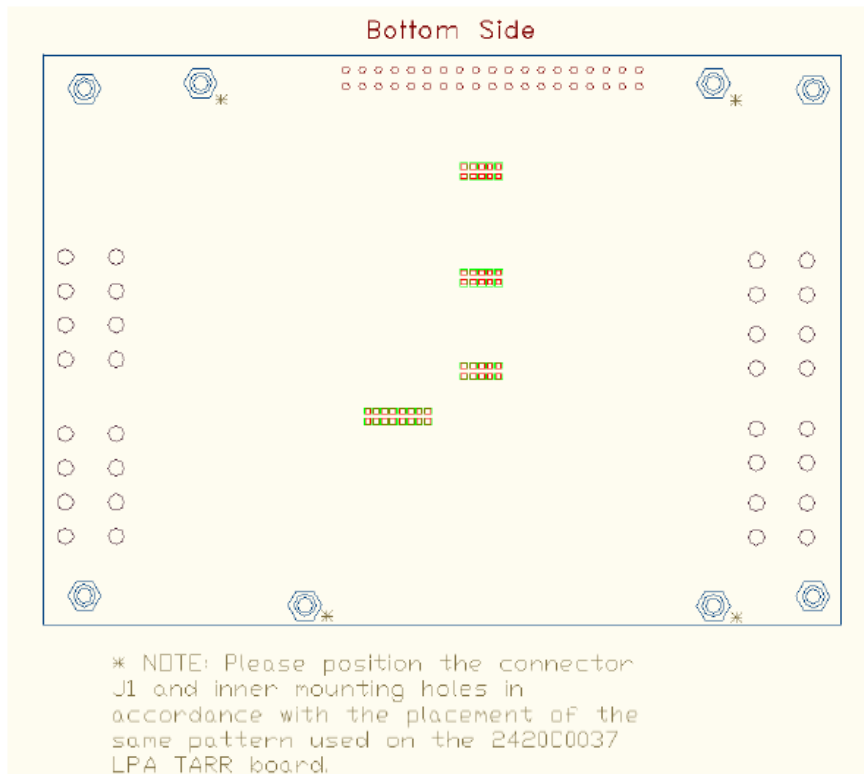

Figure 9. LP TARR power conditioner (bottom board): Bottom view

## 2.2. Service Vessel Sensors

### 2.2.1. EK-60 and EK-80 Active Acoustics

The EK-60 or EK-80 multibeam echo sounders provided by the University-National Oceanographic Laboratory System (UNOLS) fleet of vessels gathered the active acoustic data for the ADEON program. Section 5 provides details of these sonars.

### 2.2.2. Conductivity-Temperature-Depth

The standard oceanographic CTD available on the UNOLS vessel used for the bottom lander service trips provided local full-water-depth CTD data for ADEON.

### 2.2.3. Net-tows

The ADEON project used complementary set of nets to sample zooplankton and nekton in the water column. The fish and zooplankton collected with the nets served as truth data that validated our analysis of the echo sounder data. Ring nets (30–75 cm net diameter) with fine mesh (~300–500  $\mu$ m) were vertically deployed to capture small zooplankton. A 5 m<sup>2</sup> Isaacs-Kidd (Devereux and Winsett 1953) mid-water trawl (alternatives include a Methot (Methot 1986) and Neuston (David 1965)), equipped with a coarser mesh (1–5 mm) targeted specific scattering layers or features in the water column that were detected using the ship-board multi-beam echo sounders. Samples were measured, enumerated, and identified to taxonomic categories based on their acoustic scattering characteristics. Net deployment and processing methods can be found in Harris et al. (2000). Wiebe and Benfield (2003) provide a review of different net methods, which may also be helpful.

### 3. ADEON Bottom Lander Locations and Design

#### 3.1. Deployment Locations

The ADEON mandate requires measurements of the soundscape and ecosystem between 100–1000 m water depth in the Mid and South Atlantic OCS (Virginia to mid-Florida). Considerations for the ADEON site selection included:

- Providing good north-south and east-west coverage of the project area.
- Providing an even distribution of ranges between long-term acoustic recorders (AMAPPS and ADEON) for evaluation of the portability of soundscapes.
- Locating at least two bottom landers north of Cape Hatteras, which has significantly more biologic activity than south of Hatteras.
- Locating two recorders within deep water coral areas to assess if these areas have complex soundscapes similar to coral reefs within the photic zone.

Figure 10 shows the selected locations, approved by BOEM, NOAA NMFS, NOAA Office of Protected Resources, and the US Navy. These locations provide a distribution of distances between ADEON and additional recorders (Tables 5, 6, and Figure 11), which should allow for assessing the soundscape portability distance. Soundscape portability distance is a measure of how far from a measured location the soundscape remains similar, according to the soundscape metrics employed. The Wilmington and Savannah Deep bottom landers are near known deep water coral sites (Iophelia at Wilmington and other corals at Savannah Deep).

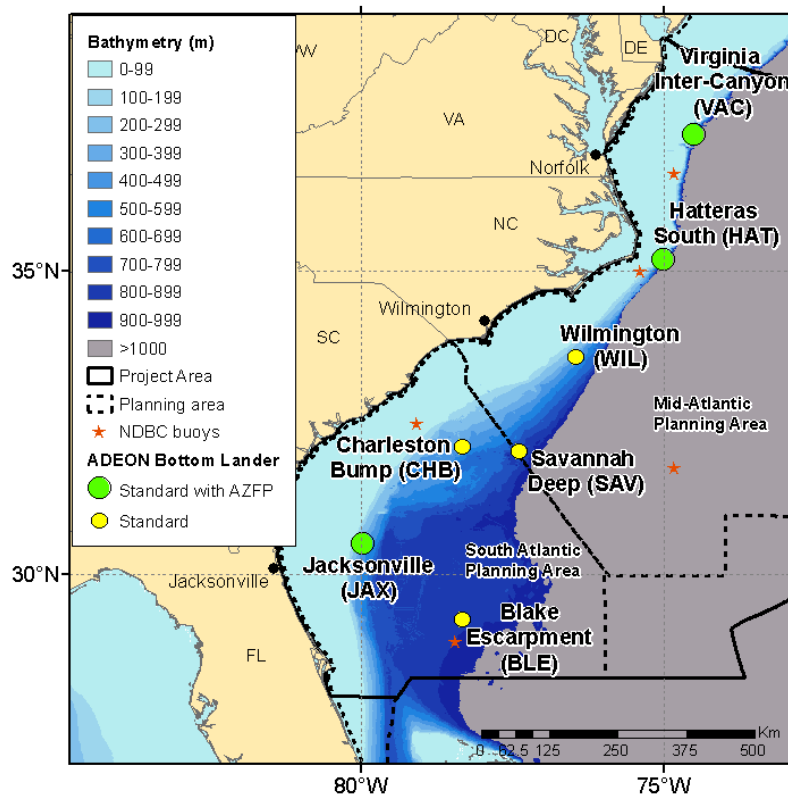

Figure 10. ADEON bottom lander locations. Locations of the NBDC buoys are shown for reference.



Table 5. ADEON bottom lander locations and water depths. Locations shallower than 400 m have the acoustic fish and zooplankton profilers. The actual lander positions were measured by ‘boxing-in’ the location using the ping-response feature of the acoustic releases (Warren et al. 2018a). VA2 indicates the second deployment of the Virginia Inter-Canyon (VAC) lander.

Location	Latitude (°)	Longitude (°)	Depth (m)
Hatteras South (HAT)	35.19968	-75.01983	296
Wilmington (WIL)	33.58524	-76.45056	461
Savannah Deep (SAV)	32.04371	-77.34657	790
Blake Escarpment (BLE)	29.25087	-78.35180	872
Jacksonville (JAX)	30.49400	-80.00233	317
Charleston Bump (CHB)	32.07052	-78.37308	404
Virginia Inter-Canyon (VA2)	37.24621	-74.51316	212

Table 6. Additional acoustic recording locations.

Location	Latitude (°)	Longitude (°)	Depth (m)	Program	Recorder type
HARP Cape Hatteras A	35.5791	-74.757	1176	LMR	HARP
HARP Norfolk Canyon A	37.1652	-74.4666	1116	LMR	HARP
HARP 06	33.6656	-76.0013	961	AMAPPS	HARP
HARP 07	32.10603	-77.0943	974	AMAPPS	HARP
HARP08	30.58378	-77.3907	1010	AMAPPS	HARP
NRS07	29.3336	-77.9999	873	NRS	PMEL

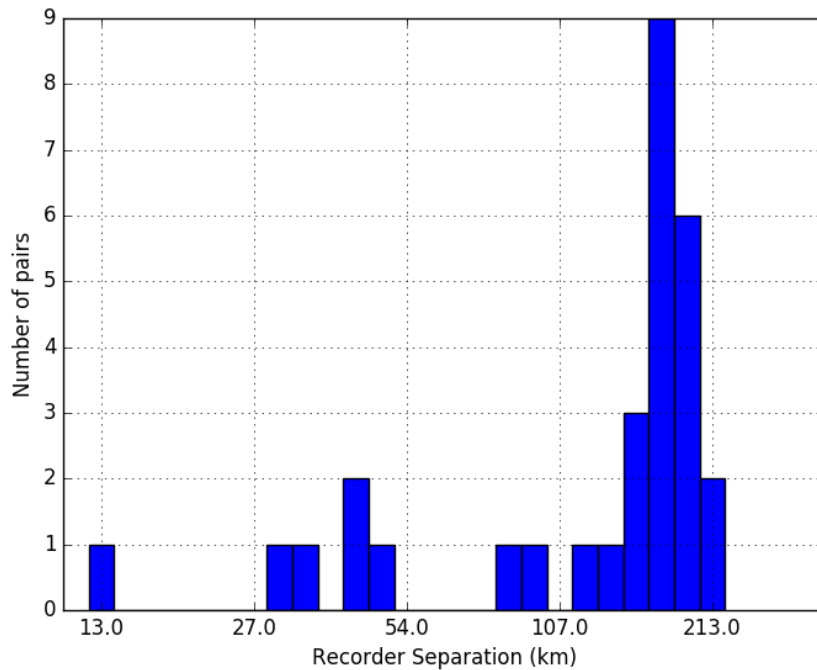

Figure 11. Histogram of ranges between all AMAPPS HARP and ADEON acoustic recorders. The X-axis is log-spaced.

### 3.2. ADEON Bottom Lander Design

The ADEON project area is within the Gulf Stream (e.g., Figure 12). These currents impose the following constraints on the bottom lander design:

- A fixed bottom lander is the simplest way to provide a stable platform for sensing particle velocity and/or acceleration, as well as instruments such as the Acoustic Zooplankton Fish Profiler (AZFP).
- It is also advisable to locate pressure sensors (i.e., hydrophones) near the bottom on a fixed lander, or else large sections of a sub-surface floating mooring would need to be treated with costly fairings to reduce vortex-induced vibrations, minimize flow noise, and prevent strum.
- It shall have transponders or some other method to localize the bottom lander after deployment, as significant cross-range drift may occur during deployment.
- It shall have retrieval locating aids, as significant cross-range drift may be expected on retrieval, creating a large search radius.
- Acoustic propagation modeling showed that due to the generally down-ward refracting sound-speed profile the sea-bed is desirable location for soundscape measurement (Figure 13).

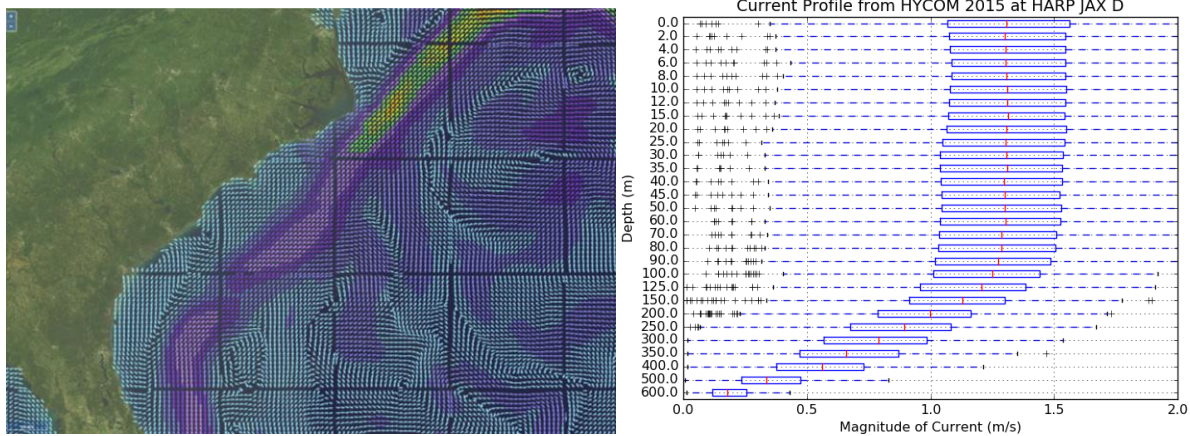

Figure 12. (Left) Sea surface currents in the project area on 18 Jul 2017 showing the Gulf Stream as purple-green-yellow and (right) distribution of daily mean current velocity as a function of depth predicted by the HYCOM model for 2015 at the site of Duke/USN recorder JAX-D.

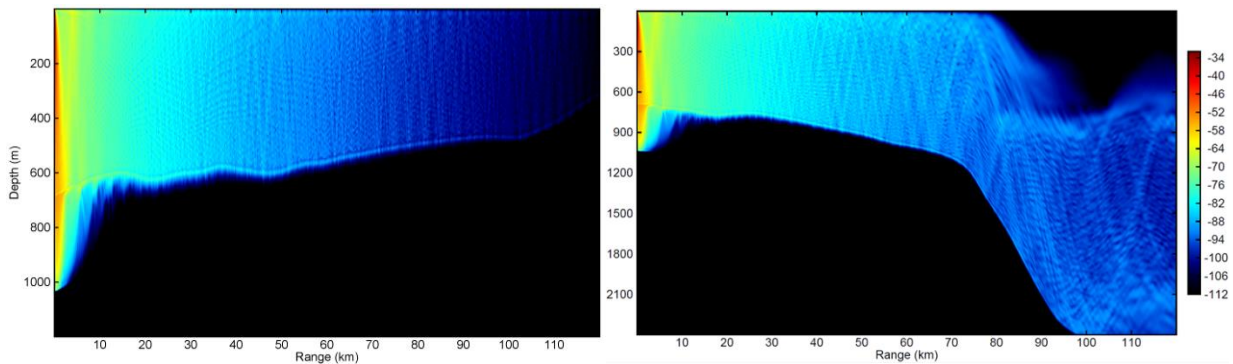

Figure 13. Acoustic propagation loss modeled for a 50–150 Hz source located at 10 m water depth above the Charleston Bump. (Left) propagation to the west of the recorder location. (Right) propagation to the east of the recorder location.

To minimize flow and movement noise in the acoustic recordings from the Gulf Stream currents, ADEON used a bottom lander (Figure 14). The frame was largely composed of high-density polyethylene plastic, which will not corrode. Due to its tight pore structure, it is also a very poor substrate for biologic growth. JASCO evaluated the mechanical strength of the material and found that a four-inch section like the planned joint at the tetrahedral super-structure yields at 55.6 kN. The bottom lander includes a dual acoustic release that holds an expendable steel anchor frame to the rest of the bottom lander (Figure 14). The bottom lander was evaluated on three separate trials to verify its mechanical and acoustic performance.

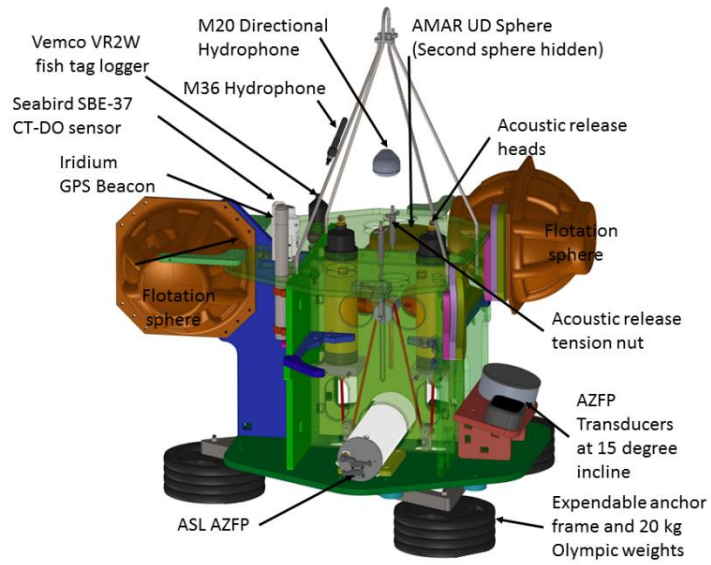

Figure 14. (Left) Bottom lander cut-away identifying the hardware components and (right) ADEON bottom lander on the deck of R/V *Odyssey* during trials in June 2017. The cylindrical flow shield around the M20 directional sensor that isolates it from flow is not shown in these images.

## 4. Passive Acoustic Data Recorders

The objective of this section is to define the characteristics of passive acoustic data recorders that are essential for accurately measuring soundscapes. This section addresses four subjects:

1. The functional blocks of passive acoustic data recorders.
2. The distance that a hydrophone must be from typical spherical and cylindrical pressure vessels.
3. Qualitative information about minimizing self-noise when designing moorings.
4. Information about quantifying the performance of passive acoustic data recorders.

There are several existing standards, good practice guides, and related publications concerning passive acoustic data recorders and measurements that this section endeavors to clarify and amplify. The order of precedence is:

1. This specification.
2. The ADEON Soundscape Specification (Ainslie et al. 2018).
3. IEEE. STD-1241-2010. IEEE Standard for Terminology and Test Methods for Analog-to-Digital Converters. DOI: 10.1109/IEEESTD.2011.5692956 (Engineers STD-1241-2010).
4. IEEE. STD-1057-2007. IEEE Standard for Digitizing Waveform Recorders (Engineers STD-1057-2007).
5. The ADEON Calibration and Deployment Good Practice Guide (Warren et al. 2018b).
6. Robinson, S.P., P.A. Lepper, and R.A. Hazelwood. 2014. Good Practice Guide for Underwater Noise Measurement. *In* National Measurement Office, Marine Scotland, and The Crown Estate (eds.). *NPL Good Practice Guide No. 133*. National Physical Laboratory. 97. (Robinson et al. 2014).
7. Sousa-Lima, R.S., T.F. Norris, J.N. Oswald, and D.P. Fernandes. 2013. A review and inventory of fixed autonomous recorders for passive acoustic monitoring of marine mammals. *Aquatic Mammals* 39(1): 23-53. [http://mhk.pnnl.gov/sites/default/files/publications/Sousa\\_Lime\\_et\\_al\\_2013.pdf](http://mhk.pnnl.gov/sites/default/files/publications/Sousa_Lime_et_al_2013.pdf). (Sousa-Lima et al. 2013).

### 4.1. Functional Blocks of Passive Acoustic Data Recorders

Figure 15 is a functional block diagram for passive acoustic data recorders. The blocks are described in the sub-sections below.

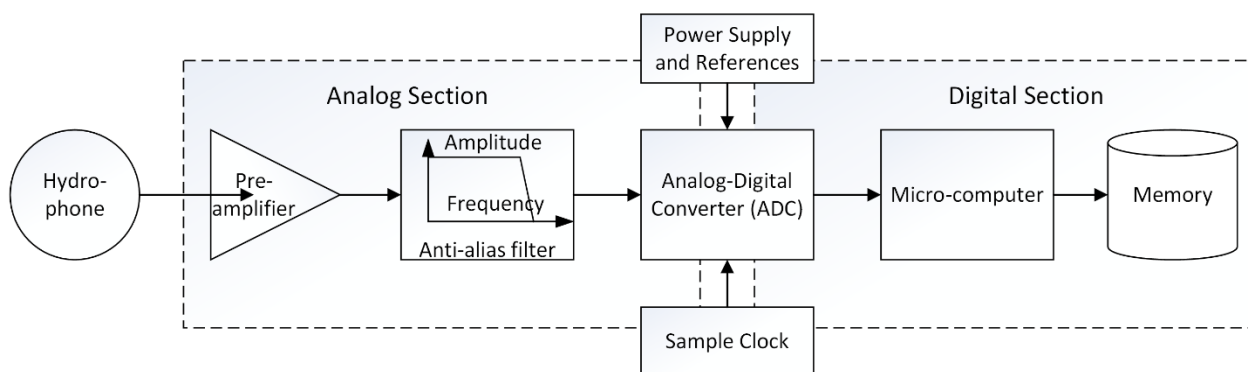

Figure 15. Block diagram of a passive acoustic data recorder.

### 4.1.1. Hydrophones

Hydrophones are transducers that convert pressure fluctuations in the water to an electrical charge. Most hydrophones include a preamplifier that converts the charge to a voltage or current that is transmitted to the analog section of the recorder.

For hydrophones with built-in preamplifiers with voltage outputs, the voltage sensitivity is specified in units of volts per pascal ( $M_V$  in V/Pa) or as a sensitivity level (relative to a sensitivity of 1 V/ $\mu$ Pa), usually expressed in decibels (dB re 1 V<sup>2</sup>/ $\mu$ Pa<sup>2</sup>).

For hydrophones that use current signaling, the current sensitivity shall be specified in units of amperes per pascal ( $M_I$  in A/Pa).

The absolute sensitivity varies slightly between hydrophones, even within the same production batch. Similarly, the sensitivity changes with frequency. Hydrophones should be purchased with a *measured* calibration curve supplied by the vendor. For accurate quantification of sound levels, the calibration curve shall be included in the analysis of sound levels (see Appendix A).

The sensitivity of the sensing element impacts the overall self-noise of the hydrophone. The hydrophone preamplifier's input referred noise should be specified as an equivalent sound pressure level in the water through the sensing element's sensitivity. The greater the sensitivity of the sensing element, the lower the hydrophone's self-noise for the same preamplifier input referred noise.

Hydrophones have a range of amplitudes over which their output is linearly related to the input pressure. Extreme care should be employed if the hydrophone is used outside of its linear range.

Hydrophones can be modeled as a voltage source in series with the sensor's capacitance or a charge source in parallel with the capacitance. The sensor will build a charge due to the static pressure caused by its depth or changes in depth. This charge is discharged through the preamplifier's input impedance. If the hydrophone's output is AC-coupled to the recorder's input, there is a charge time for the AC coupling during power up. For hydrophones and recorders with good low-frequency response (i.e., below 10 Hz), the input impedance is very high, and the charge and discharge times can be seconds long, during which time the hydrophone output should be discarded.

### 4.1.2. Preamplifiers

The preamplifier can be integrated into the hydrophone, and there may be a separate preamplifier that is part of the recorder. Preamplifiers can be used to:

- Buffer the sensing element from the input to the ADC.
- Amplify hydrophone signals before analog-to-digital conversion if the dynamic range of the ADC is smaller than that of the hydrophone (e.g., for the Aural M2).
- Force analog-to-digital input to exceed the maximum range of the ADC, so that the ADC reaches its maximum output before the hydrophone becomes non-linear.

The frequency response and gain of the preamplifier is required for converting the input voltage to pressure (Appendix A).

In differential input systems, the common-mode rejection ratio (CMRR) is the ratio of the signal in the output to an in-phase signal on both inputs. In an ideal system, the CMRR would be zero.

Power supply rejection ratio (PSRR) is the ratio of the signal in the output to a signal on the power supply. In an ideal system, the PSRR would be zero. When battery powered recorders write data to memory, the increased power draw can decrease the battery pack voltage enough to generate a large signal on the power supply. Hydrophone preamplifiers should buffer the outputs against this voltage change.



### 4.1.3. Analog-to-Digital Converters and Anti-Aliasing Filters

Analog-to-digital converters (ADC) create a digital representation of a real-world analog signal. They represent the continuously varying analog signal with the closest value from a discrete 'stair-case' of levels that they may generate. They are characterized by:

- The sampling rate (i.e., how many times per second the analog input is digitally sampled). By the Nyquist theorem, the Nyquist frequency of a digital sampling system (the maximum frequency that can be accurately sampled) is one half the system's sampling rate. Frequencies above the Nyquist frequency shall be filtered from the analog input signal prior to sampling, otherwise they will 'alias' into lower frequencies and the digital signal will not be an accurate representation of the original analog input.
- Maximum input voltage.
- Bit depth (i.e., the number of bits of digital resolution at the ADC output). The larger the number of bits for the same maximum input voltage, the smaller the distance between the discrete levels that the ADC can represent. Thus, a larger bit depth means higher resolution representation of the data.

The two main types of ADCs used in digital recorders are successive approximation register (SAR) and Sigma-Delta:

- SAR ADCs tend to be used for medium to high resolution applications at sample rates up to 5 MHz. They are usually a lower power option than Sigma-Delta converters for the same resolution and sample rate; however, they require external anti-aliasing filters.
- Sigma Delta ADCs use an over sampling technique whereby they sample the input with a 1-bit ADC at a very high sample rate and then digitally filter and decimate to provide an output at a lower sample rate and a higher bit width. The primary advantage of a Sigma Delta ADC is that the analog anti-aliasing requirements are greatly relaxed due to the high input sample rate.

For an ideal ADC, the number of bits in the output word places a limit on the noise floor of the converter. However, recorders with output word size greater than 16 bits, the system self-noise is usually greater than the quantization noise of an ideal ADC with that word size. Specifying an ADC with 18 or 24 bits does not necessary guarantee better system performance. An output word size may need to be specified if the processing requires a specific word length.

#### 4.1.3.1. Oversampling

With an oversampling converter, the sample rate of the ADC is at a much higher frequency than the analog bandwidth at the input. The advantages of oversampling are the lowering of the quantization noise contained within the passband and moving sampling harmonics out of the band of interest. Increasing the oversampling rate by a factor 2, then filtering and decimating theoretically increases the signal to noise level difference by 3 dB.

The system's SNR only improves if the ADC quantization noise is the limiting factor affecting the system noise. If the limiting factor is noise from other sources, such as hydrophones or preamplifiers, then increasing the sample rate will not increase the SNR.

It is easier to design analog anti-aliasing filters using oversampling techniques. The analog filter only needs to meet the requirements of the oversampling frequency. Digital techniques can then be used to filter and decimate to a lower output sample rate.

#### 4.1.4. Sample Clocks

ADC sampling rates are set by an external sample clock. The accuracy and stability over temperature and power supply variations of the sample clock depends on the type of clock or oscillator used. The initial frequency at room temperature can have a tolerance of  $\pm 50$  parts per million (ppm; i.e., 50  $\mu\text{Hz}/\text{Hz}$ ) for a standard crystal oscillator to  $\pm < 1$  ppm for a good temperature controlled crystal oscillator (TXCO) to  $\pm < 0.01$  ppm for a chip-scale atomic clock (CSAC). The TCXO and CSAC hold their accuracy over the temperature range of most underwater deployments ( $-5\text{ }^{\circ}\text{C}$  to  $+35\text{ }^{\circ}\text{C}$ ), whereas the standard crystal oscillator will vary by several additional parts per million over the temperature range.

Every one part per million error in the sample frequency equates to an error in time of 0.604 seconds per week (i.e., 30 seconds per week for 50 ppm). If the recorder needs to be time synchronized to other devices or external events, this clock drift shall be accounted for.

#### 4.1.5. Digital Sections

The digital section of a recorder assembles the digital samples into larger units that are either transmitted electronically for further use or stored to disk or other digital media (e.g., SD cards). It may also process components such as addition of error correction codes, compression, and detection of signals of interest (such as marine mammal clicks). Many recorders that employ hard disk drives stop sampling while writing from short-term buffers to the disk because the hydrophones would measure the vibrations of the disk motors and contaminate the recordings.

High-frequency switching in digital sections can create electrical noise that radiates into the hydrophone-preamplifier-ADC signal chain and appears in the recorded data. It can be a baseband signal or a higher frequency signal that has aliased into the bandwidth of the recorded data.

An often-overlooked noise source is acoustic noise generated by switching power supplies. Inductors in the power supplies can generate acoustic noise due to the magnetostriction from the alternating currents causing the inductor windings and cores to move and vibrate. Capacitors can generate acoustic noise due to electrostriction occurring when the ripple voltage in the input power causing the plates of the capacitors to move and vibrate. This noise is often undetectable in air due to the poor acoustic coupling to the hydrophone, but it can be detected when the system is deployed in water. These issues should be dealt with by re-working the system electronics.

## 4.2. Hydrophone Mounting Relative to the Pressure Vessel

The ideal acoustic recorder is a 'point-receiver' that measures the sound field without disturbing it. Underwater passive acoustic data recorders are components of moorings that include at minimum a recorder, ropes, and anchors. They often also include flotation, other sensors, retrieval beacons, and acoustic releases. The acoustic recorder comprises at least one pressure vessel for the recorder electronics and the power source, normally batteries. These structures can reflect sound and shadow the hydrophone, resulting in measurements that inaccurately represent the soundscape. These effects increase when the size of the structure is greater than or equal to the wavelength of the sound being measured.

To mitigate these effects, mooring designs should:

- Locate the hydrophones above all pressure vessels and large mooring components;
- Orient the hydrophones vertically;
- Separate the hydrophones from all pressure vessels and horizontal flat surfaces by at least 25 cm.

Recorders whose hydrophones are located on or beside a cylindrical or spherical pressure vessel may be used for characterizing the presence of marine life. They shall not be used for making calibrated ambient measurements for frequencies greater than  $c/(2L)$ , where  $c$  is the sound speed and  $L$  is the largest



dimension of the pressure vessel. Figure 16 demonstrates the importance of the hydrophone being located away from the pressure vessel.

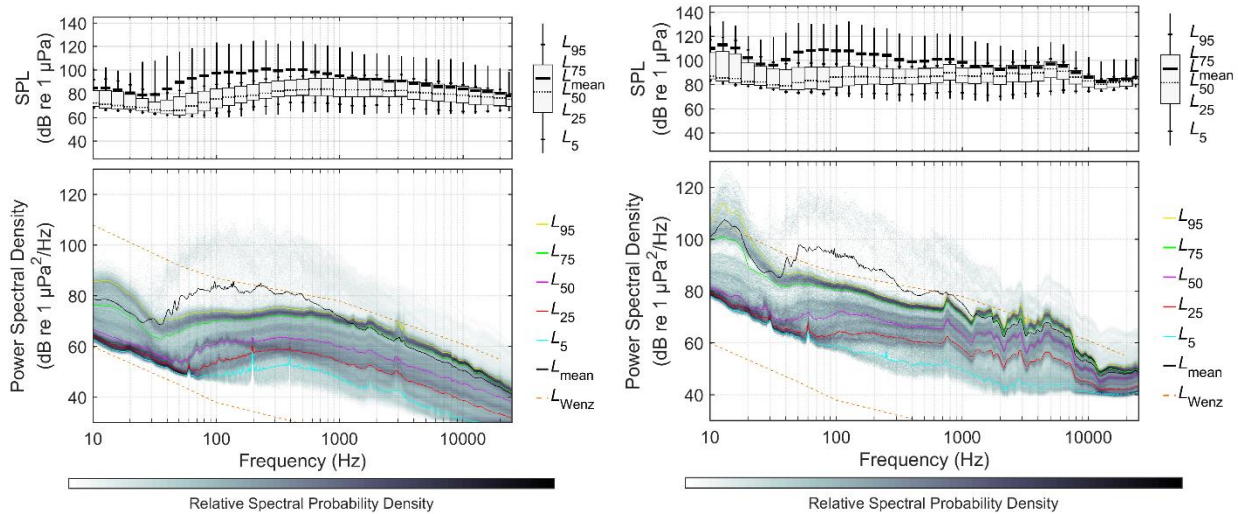

Figure 16. Percentile spectra from two recorders deployed 10 m apart for 5 days in February 2013 in 50 m of water. Only one vessel was present during the recordings for a 6 hour period. Both recorders were suspended on moorings 3 m long with a float 1 m above the recorder. The left-hand data are from a recorder with a 15-cm diameter, 70-cm long plastic pressure vessel where the hydrophone was 25 cm above the pressure vessel. The right-hand data are from a similarly shaped pressure vessel where the hydrophone was attached to the pressure vessel endcap. The deflections in the spectra are caused by constructive and destructive interference of reflected ambient sound. Similar results are obtained for recorders where the hydrophone is mounted directly beside glass sphere pressure housings. The bumps in the L95 percentile of the left-hand results at 3–5 kHz are mooring chains ~1 km from the test site. These should be visible in the right-hand side as well but are lost in the noise artifacts.

### 4.3. Designing Moorings to Minimize Self-Noise

Acoustic recordings may be contaminated by self-noise (see Figure 1 of ISO 2017) due to mooring movement, current flow around hydrophones, and noise generated by mooring components (see Section 4.3 of Robinson et al. 2014). Hydrophones are pressure fluctuation sensors. Currents moving past a hydrophone can cause pressure fluctuation vortices to form behind the hydrophone, which are recorded as if they were acoustic fluctuations (sound), even though they are caused by the current. Similarly, vertical movement of hydrophones causes a pressure fluctuation. Using the hydrostatic equation, a 1 cm vertical movement of a hydrophone results in a 100 Pa change in pressure:

$$P = \rho gh; \Delta P = \rho g \Delta h$$

$$\Delta h = 1 \text{ cm} \rightarrow P = 1040 \frac{\text{kg}}{\text{m}^3} \cdot 9.81 \frac{\text{m}}{\text{s}^2} \cdot 0.01 \text{ m} \sim 100 \frac{\text{kg}}{\text{m s}^2} = 100 \text{ Pa}$$

An oscillatory vertical motion of amplitude 1 cm therefore leads to an rms pressure fluctuation of 71.7 Pa. If the same pressure fluctuation were caused by sound it would correspond to a sound pressure level of 157 dB re 1 µPa<sup>2</sup>.

Vertical movement and equivalent changes in pressure may be caused by waves in shallow water or by horizontal movement of a moored hydrophone due to currents resulting in a vertical movement. The fundamental frequencies of vertical movement are usually low (<1 Hz); however, it generally has a turbulent frequency spectrum that falls off as frequency<sup>-5/3</sup> and can be a significant noise source at hundreds of hertz (Figure 17). In many recordings, examining the broadband sound levels aligned with the start of the tidal cycle is an easy method of visualizing whether flow noise from tidal currents is a problem (Figure 18).

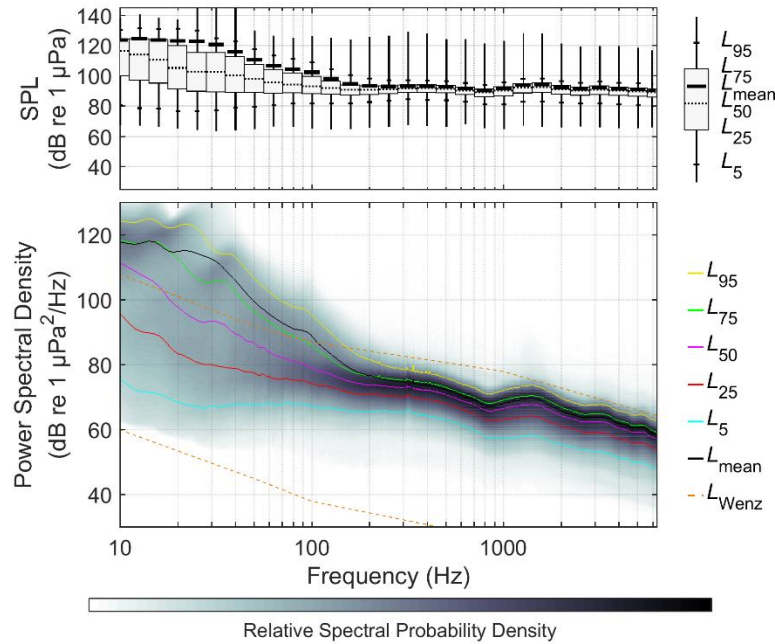

Figure 17. Example (top) 1-minute decade SPL distributions and (bottom) percentile spectra that are dominated by flow noise. The data were collected over a four-month period using a bottom lander that floated the recorder 3 m above the seabed in an area with surface flow speeds up to 2 m/s (water depth ~150 m). These measurements can not be used to characterize the long-term soundscape below ~200 Hz.

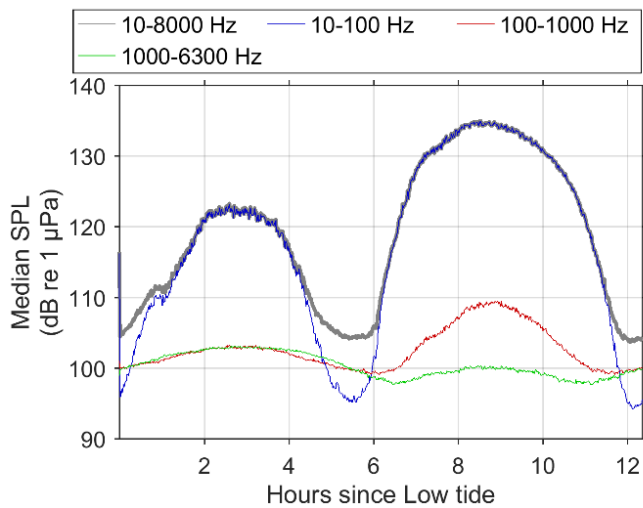

Figure 18. Data from Figure 17 aligned to the start of low tide and averaged every 5 minutes for the 4 month recording. At this location, there is more self-noise from tidal currents generated during the ebb current than the flood current, which is usual.

Moorings that fix the hydrophone position relative to the seabed, rather than suspending the hydrophone using anchors and flotation, are strongly recommended for any measurements in areas with currents greater than 0.1 m/s. The HYCOM model (see <https://coastwatch.pfeg.noaa.gov/erddap/griddap/>) can be used to estimate typical bottom currents at a project site.

It is best practice to protect hydrophones with flow shields and/or wraps that disrupt turbulent boundary layers. Similarly, supports and framework near the hydrophone should be wrapped.

## 4.4. Quantifying Recorder Performance

When quantifying the recorder performance, the complete system including the hydrophone should be evaluated. This section provides definitions for key acoustic data recorder performance metrics and guidance on how to measure them. Appendix B provides a recommended specification sheet as well as minimum specification values and the specifications of the AMAR recorders used by ADEON.

General guidance:

- When making measurement the test record should be long enough that the system has reached steady state and any effects of turn-on have settled out (e.g., Hydrophone AC settling times, Section 4.1.1). Additionally, the test record should have enough samples after the settling time for the chosen FFT size and number of averages. The settling time is determined by factors such as the time constant created by the low frequency roll-off pole and stabilization times of the power supplies and electronics. An initial recording should be made with the input to the recorder terminated with the equivalent impedance of the hydrophone to measure how long the recorder takes to stabilize to an error level that does not adversely affect the analysis.
- If the system performs periodic tasks such as writing to disk or memory, the test record should include samples of these periods to detect any artifacts they may introduce.

### 4.4.1. Signal Input & Hydrophone Testing

#### 4.4.1.1. Noise Testing

It can be difficult to evaluate system noise with a working hydrophone. The hydrophone shall be placed in an anechoic environment with an ambient noise below the hydrophone's self-noise. An alternative is to use a dummy hydrophone that has the same preamplifier as the actual hydrophone, but instead of being connected to a transducer, it terminates with the equivalent transducer impedance. Should a dummy hydrophone not be available, the recorder can be terminated with the equivalent output impedance of the hydrophone and its noise measured. To obtain the total system noise, the hydrophone noise (as specified by the hydrophone vendor) should be added to the recorder noise by taking the square root of the sum of the squares of the two rms noise voltages.

The measurements shall be made at the same sample rate to be used during the deployment because sample rate can impact the quantization noise contribution of the ADC and possibly introduce undesired artifacts.

The hydrophone and recorder should be shielded from RF interference.

#### 4.4.1.2. Frequency Response

Special facilities are required to verify the frequency response of a hydrophone and recording system. Reflections of the test signal from seafloor and surface or the walls of a test tank limit the time available to make a measurement. For accurate measurements, a hydrophone-specific calibration from a specialized testing facility should be obtained from the hydrophone vendor. The calibration shall be included in the data analysis (see Appendix A).

Sensitivity testing at spot frequencies can be accomplished using calibration instruments, such as pistonphones, that generate a known source level at a specific frequency. The typical frequencies for spot calibrations are 100 and 250 Hz. The results of the spot calibration may then be used to move the entire calibration curve to account for small changes in sensitivity over time.

The frequency response of the hydrophone may change over time due to aging of the sensing element and due to moisture migrating through the protective covering. The first indication of moisture reaching the sensing element is an increase in the low-frequency roll-off due to leakage across the sensing element. As the leakage across the sensing element increases, the fundamental sensitivity of the hydrophone can be reduced.

The hydrophone sensitivity should be verified immediately after retrieving the system from the water, before the moisture can migrate out of the protective covering. The low-frequency response of the hydrophone should be verified after long deployments (greater than 2 months) for each hydrophone model until the moisture protection can be verified. The frequency response of the recorder should not change over time.

#### 4.4.2. Data Analysis

The fast Fourier transform (FFT) is a mathematical method for converting the sampled data from the time domain to the frequency domain. The parameters in the following subsections should be considered when setting up the FFT analysis.

##### 4.4.2.1. FFT Windowing

Windowing is required to prevent spectral leakage when analyzing the data using an FFT. The output of the FFT shall be corrected for the effect of the window function. When processing the data to calculate the level of tones, the results should only be corrected for the window function, not the FFT bin width. When processing the data to calculate the spectral noise floor, the results should be corrected for both the window function and the FFT bin width. Thus, it is not possible to correctly calculate both the tone level and the noise floor with the same calculation. Additionally, different window functions are more suited to tones (flat top) and noise (Hann).

To correct for the window function, multiply the mean square value by the square root of the sum of the squared window function amplitudes divided by the number of points in the window. To correct for the FFT bin width, divide the mean square value by the square root of the FFT bin width.

##### 4.4.2.2. Averaging

When using averaging to smooth the FFT data, overlapping FFTs should be used to ensure that no data is missed due to the windowing. Averaging will not change the noise floor; it will only reduce the variance of the FFT results.

#### 4.4.2.3. FFT Resolution

The choice of FFT length relative to the sample rate will depend on the desired frequency resolution required by the analysis. The frequency resolution of the FFT is:

$$R = \frac{F_s}{N_{\text{FFT}}},$$

where  $F_s$  is the sampling rate and  $N_{\text{FFT}}$  is the number of points in the FFT.

#### 4.4.3. Data Acquisition System Parameters

There are wide variety of parameters that describe the performance of a data acquisition system. The ADEON Terminology Standard (Ainslie et al. 2017) defines the following terms:

- DR—dynamic range;
- SFDR—spurious-free dynamic range;
- rms noise—root mean square noise;
- spectral noise floor;
- THD: total harmonic distortion;
- full-scale signal;
- non-acoustic self-noise;
- SNR: signal to noise ratio;
- SNPR: signal to noise power ratio;
- IMD: intermodulation distortion; and
- SiNAD: signal to noise and distortion.

#### 4.4.4. System-level Parameter - Crosstalk

In multichannel systems, crosstalk is the undesired signal level in an undriven channel due to the signal level in a driven channel. Crosstalk causes errors when bearings are calculated from the relative signal strengths in the different channels. Crosstalk is often frequency dependent, an usually increases with frequencies.

To measure crosstalk, terminate the channel to be tested with equivalent impedance of the hydrophone. Place the unit in an electrically shielded environment. Inject an in-phase signal into all other channels, with amplitude one half of a sinusoidal full-scale signal. Measure the signal level in the terminated channel. This test should be repeated at multiple frequencies across the band of interest. The test should be repeated for each channel.

## 4.5. System Performance

### 4.5.1. Maximizing Dynamic Range

To maximize the dynamic range of the system, the maximum linear output of the hydrophone should be matched to the maximum input of the ADC. Often the gain of the hydrophone becomes non-linear before it hard limits, or clips. Matching the maximum linear output of the hydrophone to the maximum input of the ADC causes the ADC to hard limit before the hydrophone becomes non-linear. Hard limiting makes it easier to identify overload conditions in the data.

### 4.5.2. Overload

When selecting a hydrophone and ADC system its dynamic range shall be matched to the expected minimum and maximum signal amplitudes. The free-field hydrophone sensitivity should be selected to prevent the voltage at the ADC from exceeding its maximum input. It is not only the peak signal voltage at one frequency that can cause overloading. The broadband sound pressure that the hydrophone is exposed to should not exceed the maximum that the hydrophone and ADC can linearly convert to the digital representation. Once one stage in the signal chain overloads, linear filtering later in the signal chain will not correct the problem, it will only mask that the problem has occurred.

Recovery from overload is important. If a signal larger than the system can convert is received, it is important to know how quickly the system recovers from the overvoltage event.

### 4.5.3. Dominant Noise Source

The dominant noise source is determined by comparing the output referred noise of the hydrophone to the ADC input referred noise. The larger of the two is the dominant noise source. Since the ADC spectral noise can depend on sample rate (the spectral noise floor reduces by 3 dB for every doubling of the sample rate), the dominant noise source may depend on the sample rate. At lower sample rates, the ADC may be the dominant source. At higher sample rates, the hydrophone may be the dominant source.

If the recorder noise floor is measured without the hydrophone, it is important to know how the hydrophone noise contributes to the noise floor of the system. The system noise is sometimes expressed as an equivalent sound pressure level (dB re  $1 \mu\text{Pa}^2$ ), which is the SPL that in the absence of sound would result in the same rms noise voltage at the system output as the rms system noise voltage.



## 5. Active Acoustic Recorders

This section defines the characteristics of echo sounder systems that are essential for accurately measuring fish and zooplankton biomass using acoustic backscatter from the water column and to describe the hardware selected for ADEON. This section discusses:

1. Remotely deployed echo sounder systems
2. Vessel mounted echo sounder systems

Echo sounders measure and record acoustic returns from the ocean bottom and scatterers in the water column. Scatterers can be biological (fish, zooplankton) or geophysical (sediment, gas plumes) in nature. A time clock triggers pulses at a specified rate to the transmitter (Figure 19(1)). The transmitter produces an electrical ping of specified duration and frequency (Figure 19(2)). The transmitter output is received by the transducer as electrical energy and is converted to acoustic energy (or pressure). The acoustic energy is emitted from the transducer into the water column and propagated within the echo sounder beam (Figure 19(3)). The width of the echo sounder beam is inversely proportional to the frequency of the pings generated. Nominal 3 dB beamwidths for single beam echo sounders are typically 5–15°. When the propagating pulse encounters a target in the water column, reflected energy (or echo) is bounced back to the transducer. This backscattered energy or echo is received by the transducer and converted to electrical energy (Figure 19(4)). The receiver generates the time difference between the electrical signal emission and return for determining distance, and the signal is amplified for display or storage (Figure 19(4–5)).

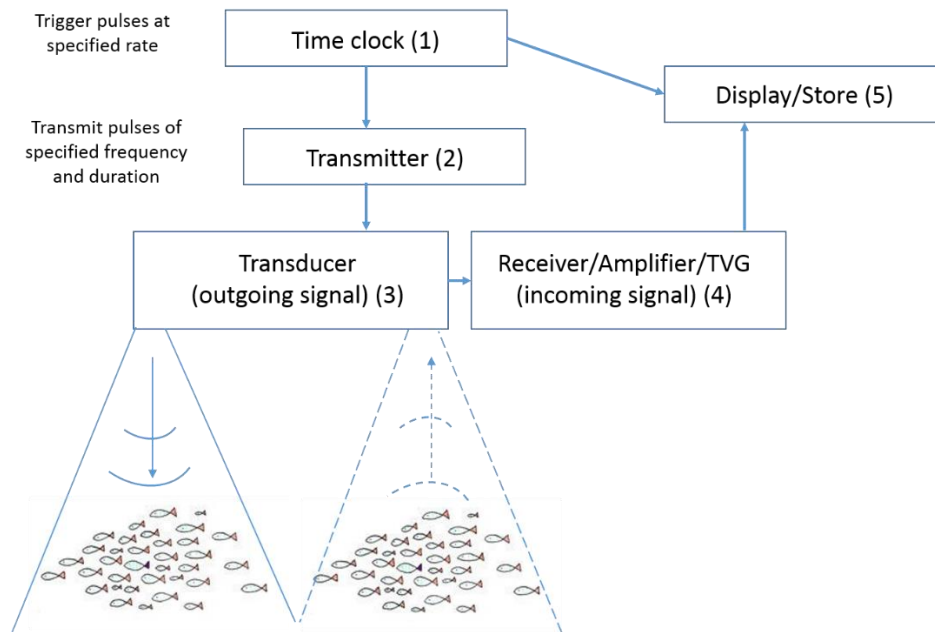

Figure 19. Generalized concept of a downward looking echo sounder. Remotely deployed echo sounders can also be positioned looking upward or sideward. Returning echoes can be viewed as an echogram on a display or stored within the system for future analysis.

There are three basic categories of scientific echo sounder transducers: single-beam, split-beam, and multi-beam. Single-beam systems are widely-used and cheaper than the other two systems. The data they collect is used to estimate volume backscatter strength ( $S_V = 10 \log_{10} s_V$  dB, where  $s_V$  is the volume backscattering coefficient in  $m^{-1} sr^{-1}$ ), which is the volume differential scattering cross section per unit volume, a measure of echo energy for a unit volume of water. Split-beam systems are more expensive, but the received signal is measured along four (or in some cases three) sub-sections of the transducer face. This approach allows split-beam systems to measure the phase difference in the echoes received

by the different quadrants, which produces backscatter measurements of single targets within the volume of water ensonified. Thus split-beam systems can collect target strength (TS) measurements (including the 3-D position of these targets) in addition to  $S_V$  data. The positional information of the TS measurements can be very powerful and may allow for deeper analysis of the data such as tracking the movement of individual targets over multiple pings thus providing information on the behavior of some targets. Multi-beam systems are usually thought of as bottom-mapping sonars; however, there are several models that can collect water column backscatter data ( $S_V$ ). Many national fishery survey vessels are equipped with these systems. These systems can collect 3-D swaths of the water column, sampling much larger volume of water compared to the smaller beamwidth single- and split-beam systems. However, these systems are larger, more expensive, require fine-scale position and attitude sensor integration, and since targets may be ensonified at angles off-of-vertical (relative to single- and split-beam systems), the interpretation of multi-beam water column backscatter data can be challenging.

## 5.1. Remotely Deployed Echo Sounder Systems

### 5.1.1. Remote Deployment Hardware Limitations and Trade-offs

Remotely deployed echo sounder systems can be deployed in a downward, upward, or sideward looking position. In deployment regions where a surface expression increases overall risk to the instruments, echo sounder systems are typically deployed on a bottom lander looking up or within a sub-surface mooring line oriented slightly off vertical to minimize interference from sensors higher up on the mooring line. ADEON is integrating a single-beam, multi-frequency echo sounder system into 3 of the 7 bottom lander platforms. The transducers are mounted at an approximate 15° angle off vertical to eliminate interference from the lander sensors and flotation mounted above the transducers (Figure 14).

The remote deployment of an archival echo sounder system requires a trade-off between power and storage space. Flexibility in battery power comes from balancing the instrument duty cycle, ping rate per sampling cycle, ping duration, and onboard processing (i.e., averaging before storing). Internal storage is maximized through the balance of duty cycle, ping rate per sampling cycle, sampling range, averaging (temporal and spatial resolution). The maximum possible sampling range is determined by the size of the internal data buffer and internal analog-to-digital (A/D) sampling rate. Storage space can also be conserved in some systems by specifying a lockout range. A lockout range can be specified for the region directly in front of the transducer where electronic “ringdown” renders the data unusable. Alternatively, if the user is only interested in a specific depth of the water column, a lockout range can be specified to exclude unwanted regions of the water column.

### 5.1.2. Selected Remote Deployed Echo Sounder System: Acoustic Zooplankton Fish Profiler (AZFP)<sup>1</sup>

The AZFP (ASL Environmental Sciences) is a self-contained instrument designed to measure and record acoustic returns from the water column. The AZFP can be deployed in depths up to 600 m in its anodized aluminum underwater pressure housing and will operate for extended periods up to a year with its internal battery. A deep-water version is available up to 6000 m with advance special order. The instrument is equipped with up to 4 echo sounder channels, each operating at a different acoustic frequency. The ADEON AZFPs will contain transducers operating at 38, 125, 200, and 455 kHz. A four-frequency system was selected to maximize the amount of information provided for determining community structure from multiple scattering groups. The transducers for each frequency all have similar nominal beamwidth of 7–8°, except for the 38 kHz beam, which has a beamwidth of 12° (Table 7). Because the attenuation of the emitted sounds increases with distance to the surface (Table 7), the AZFPs were only deployed on the

---

<sup>1</sup> All technical specifications, tables, and figures related to the AZFP were obtained from the AZFP Operator’s Manual and compiled here for simplicity. AZFP Operator’s Manual GU-100-AZFP-01-R27



three shallowest ADEON bottom landers (Table 5) so that at least three of the frequencies sampled the full water column.

For each frequency, the AZFP transmits a series of acoustic pulses of programmable duration. In between each pulse the instrument listens for the echoes from targets in the water column up to a programmable distance from the instrument. The AZFP stores acquired data within its non-volatile 32 GB CompactFlash memory. Communicating with the AZFP and downloading of data occurs via an RS-232 (or optional RS-422) interface through a bulkhead connector on the pressure housing. An alternative download method is to remove the instrument from its pressure case, eject the CompactFlash, and use a USB card reader to transfer the data to a PC.

### 5.1.2.1. Deployment Configuration Options

The AZFP systems can be deployed in multiple configurations: upward, downward, or sideward looking orientations (Figure 20). ADEON deployed the AZFPs on bottom landers where the main sensor housing was deployed lying down in a horizontal position, while the transducers were deployed in an upward looking orientation 15° off vertical to eliminate interference from the lander floatation mounted above the transducers (Figure 14).

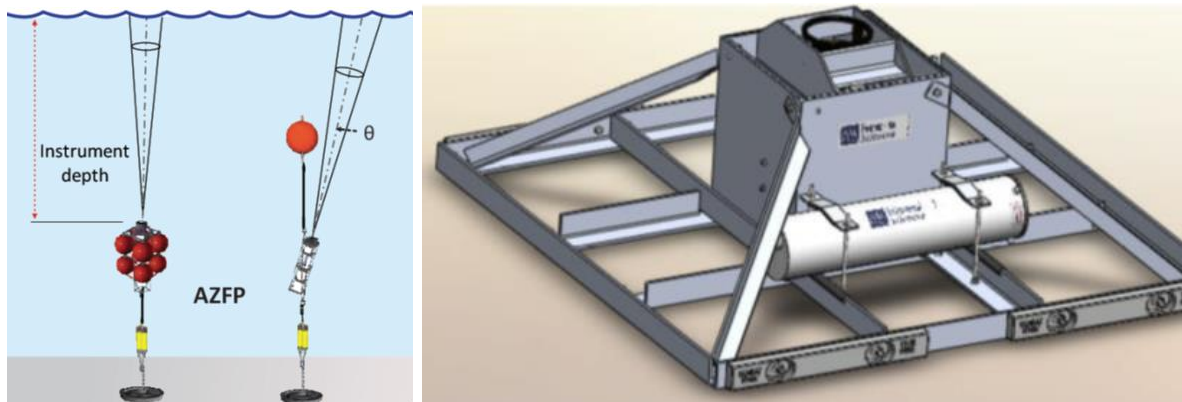

Figure 20. (Right) Two typical sub-surface bottom mooring deployment configurations. (Left) bottom lander deployment configuration where the AZFP instrument is deployed in a horizontal position, while the transducers are deployed in an upward looking orientation. ADEON deployed the AZFPs in a bottom lander mode with transducers deployed 15° off vertical to eliminate interference with the lander floatation. Note that this right-hand figure is a typical deployment, however, for this project the AZFP is deployed as shown in Figure 14.

The AZFP units properly measure instrument orientation when the instrument is upright (i.e., the end cap of the pressure case is oriented toward the surface when the instrument is submerged). This orientation is referred to as the “Upward-Looking Pressure Case” orientation. The instrument properly senses and records orientations that differ  $\pm 45^\circ$  from this orientation with an accuracy of  $\pm 3^\circ$ . It is important to note that instrument orientation data is recorded, not transducer orientation (which may differ if the transducer is remotely located). Specific to ADEON, the AZFPs are in a bottom lander with the orientation sensor aligned horizontally with the pressure casing. This renders the orientation information of the sensor void.

### 5.1.2.2. Sensors

The ADEON AZFPs are equipped with 4 transducers (38, 125, 200, and 455 kHz). The transducer elements are manufactured by AIRMAR Inc and have source levels and beamwidths shown in Table 7 (where they are referred to as “nominal source level” and “nominal -3 dB beam angle”). Each echo sounder channel is equipped with a high-dynamic-range, logarithmic-response receiver that eliminates the requirement for time-varying gain. The AZFP receiver filters the transducer signal to only retain energy in the frequency band of the transducer emission. The dynamic range (Ainslie et al. 2017) for each channel of the selected ADEON transducers is >85 dB. The estimated minimum detectable volume backscattering strength ( $S_V$  in dB re  $1 \text{ m}^{-1} \text{ sr}^{-1}$ ) for each transducer frequency is shown in Table 7. A Certificate of Calibration was provided by the manufacturer for each transducer upon delivery (e.g., Figure 21).

Table 7. AZFP acoustic characteristics given by transducer frequency (from the AZFP User’s Manual). Spatial sidelobes suppression is 15 dB or better outside the nominal beamwidths. Limits of detectable volume backscatter strength are estimates, and individual units may vary by  $\pm 3$  to 4 dB. Receiver dynamic range is >85 dB for each channel (\* receiver dynamic range is 75 dB for 2000 kHz). Volume backscatter is calibrated to  $\pm 1$  dB, and Sv resolution is  $\pm 0.1$  dB. Reference values are  $1 \propto \text{Pa}^2 \text{ m}^2$  for source level and  $1 \text{ m}^{-1} \text{ sr}^{-1}$  for volume backscattering strength. The nominal source level and nominal -3 dB beam angle are the source level and beamwidth that the transducers are designed to have; calibration is recommended to confirm these parameters.

Estimated Minimum Detectable Volume Backscatter Strength (dB)												
Frequency (kHz)	Nominal Source Level(dB)	Nominal -3dB Beam Angle	1m	2m	5m	10m	20m	50m	100m	200m	300m	500m
38	208	12	-136	-130	-122	-116	-110	-101	-94	-87	-82	-74
67.5	205	10	-131	-125	-117	-110	-104	-95	-87	-77	-70	-58
125	210	8	-136	-129	-121	-115	-108	-98	-88	-75	-64	-
200	210	8	-130	-124	-115	-109	-102	-91	-79	-63	-48	-
333	211	8	-121	-115	-106	-100	-92	-79	-65	-43	-	-
455	210	7	-116	-110	-101	-94	-86	-71	-54	-	-	-
769	210	7	-106	-99	-90	-81	-71	-48	-	-	-	-
2000*	212	7	-80	-71	-55	-	-	-	-	-	-	-

### AZFP Certificate of Calibration Version : 12.0

10/26/2016	Operator: <b>Jay Milligan</b>	Unit Serial Number: <b>55127</b>
------------	-------------------------------	----------------------------------

Sonar Channel #1:					
Frequency:	38.0 KHz	Transducer Part#:	E23D20	Transducer Serial#:	157
<b>OCV:</b> Voltage on reference:	8.8	Reference TVR:	145.9	Transducer Voltage:	0.248
<b>TVR:</b> Voltage on transducer:	173	Reference OCV:	-213.2	Reference Voltage:	2.0
System Gain and Linearity:					
Voltage on Reference	A/D Counts (N)	Calibration Values	Units	Sphere Check	Units
*	65000	TVR	174.5	Water Temp	10.12
-10dB	59000	VTX	61.2	Range	310
-20dB	53040	BP	0.02	Measured	-51.3
-30dB	47080	Echo Level	144.3	Expected	-51.0
-40dB	41100	Slope	0.0228	Error	-0.3
-50dB	Not Measured				
*This voltage is adjusted to bring N between 64950 and 65050 counts All measurements with 1.0 meter separation in 20°C fresh water unless otherwise noted.					

Figure 21. Example Certificate of Calibration provided for a 125 kHz transducer within the AZFP system. OCV (for “open-circuit voltage”) is the hydrophone sensitivity level in dB re 1 V<sup>2</sup>/μPa<sup>2</sup>. The “Calibration Values” are integrated into the AZFP operation software as unique instrument parameters. The “Sphere Check” lists the results of a target strength calibration measurement, comprising the water temperature (10.12 °C), the distance from the sonar to the target, the measured target strength (–51.3 dB re 1 m<sup>2</sup>/sr), and the target strength of the calibration sphere (–51.0 dB re 1 m<sup>2</sup>/sr). The error value (–0.3 dB) is the difference between the “Measured” and “Expected” values of target strength.

The AZFP should include the following context sensors for interpreting the data:

- Real-time clock for time-stamping the collected data. The resolution and drift (e.g., seconds per day) of the clock should be specified;
- Orientation sensor: X and Y tilt sensors are needed to know the orientation of the AZFP beam relative to vertical;
- Thermistor: A thermistor is used to record temperature during an AZFP deployment which provides information on the sound speed near the recorder.

#### 5.1.2.3. Programming/Processing Considerations

The AZFP has multiple user-selected operation parameters to maximize data collection for a pre-defined mission. The AZFP is programmed using the custom AZFP communication software (AZFPLink) to start data collection immediately, or to wake up at a future time. The AZFP offers the pre-programming of up to 12 deployment phases by date or duration with repeat and sleep features. Pulse lengths are selectable from 100 to 1000 ms. The ping rate within each phase is also user specified up to 1 Hz depending on frequency and range. Figures 22 and 23 illustrate sample user-specified deployment phases for programming burst interval, pings per burst, pulse length, digitization rate, ping period, lockout range, maximum range, and averaging options using the AZFPLink terminology as summarized in the ADEON Terminology Standard (Ainslie et al. 2017).

The AZFP offers three A/D digitization rates: 64, 40, or 20 kHz. The maximum possible sampling range is determined by the size of an internal data buffer and the internal analog-to-digital (A/D) sampling rate: it is

~160 m at a sampling rate of 64 kHz, 255 m at 40 kHz, and 510 m at 20 kHz. The effective maximum range may be much less than the nominal maximum, depending on the acoustic frequencies used by the instrument. The maximum range for the higher frequencies will be limited by the dynamic range of the sonder detection system and acoustic propagation effects (see Table 7). The AZFP is also equipped with a range lockout feature to disregard transducer ringdown or close targets.

The AZFP has the capability to perform received data averages in range (minimum bin size is 0.011 m), time, or both. Recorded counts are related to the target strength or volume backscattering strength in the water column that produced the echo signals recorded by the instrument. Frequently, considerations of data storage space or power consumption make it advantageous to store averaged data rather than the individual digitized values. The user may specify averaging over a specified range interval or number of samples, time-averaging over all the pings in a burst, or a combination of the two. Since the recorded values of  $N$  are proportional to the logarithm of the echo intensity, they should not be directly averaged (the result would in that case be the geometric rather than the arithmetic mean). The AZFP performs a true arithmetic average of the signal power data and stores the result as the data are being collected. The individual raw samples are not saved. Because of the limitations of the on-board processor and integer arithmetic, the conversion between logarithmic and linear values is done using a look-up table, which has a resolution of 0.013 dB. The averages are stored in linear form on board.

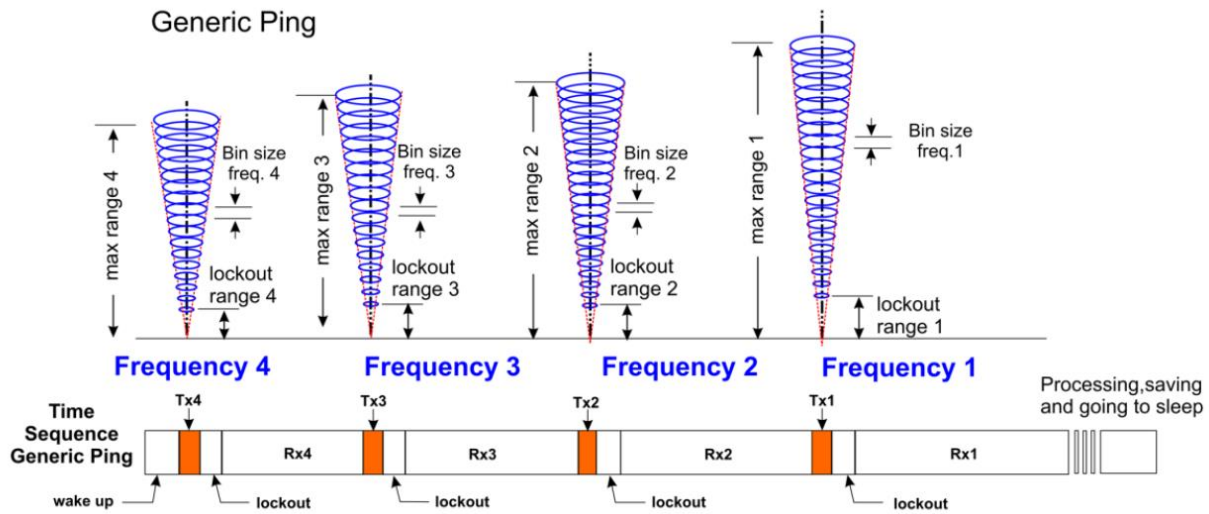

Figure 22. Illustration of a generic ping for a 4-channel AZFP and its associated timing. From Lemon et al. (2012), reproduced with permission.

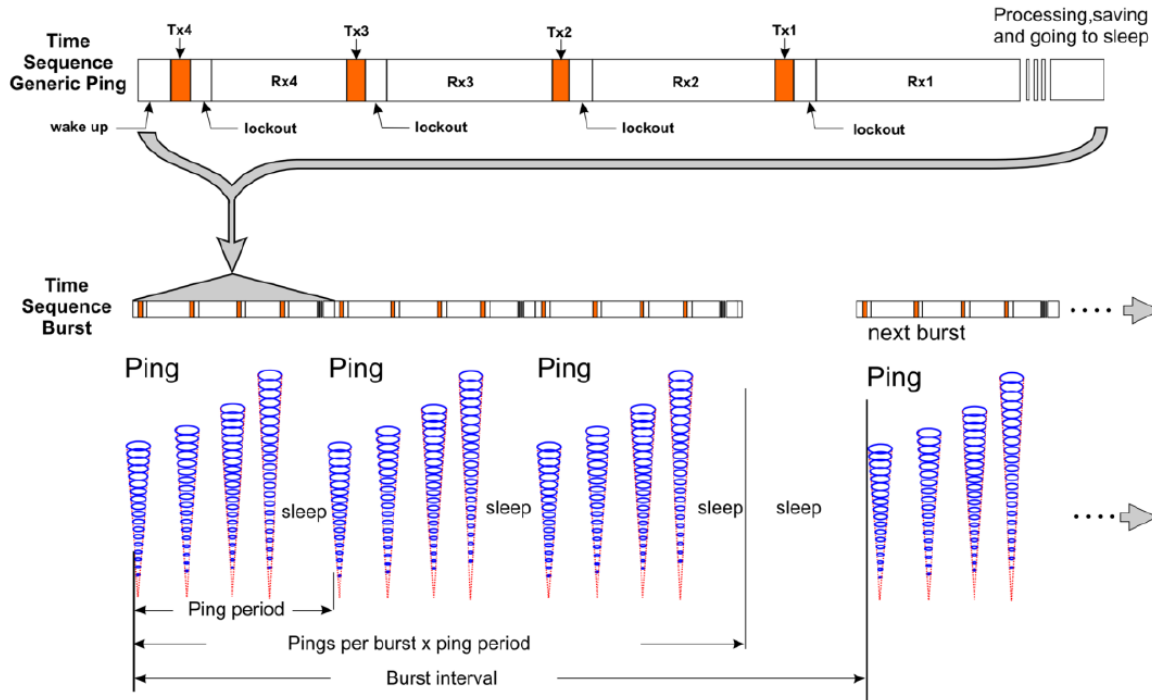

Figure 23. Illustration of burst interval sampling over a single deployment phase. From Lemon et al. (2012), reproduced with permission.

## 5.2. Vessel mounted echo sounder systems

### 5.2.1. Vessel-mounted Hardware Limitations and Trade-offs

Vessel-mounted systems allow for greater spatial survey coverage at the expense of only sampling at a small number of time intervals. Vessel mounted systems are also not constrained for power or storage and therefore can provide higher resolution measurements, especially when multi-beam systems are employed. There are three methods of deploying vessel mounted systems:

- Hull-mounted systems offer many benefits including: fixed position of the transducers relative to the ship; protected location; and cable-runs are in protected space. In addition, lower frequency, narrow-beamwidth transducers (i.e., 18 and 38 kHz, <math><20^\circ</math> beamwidth; beamwidth is the angular extent of the beam, in degrees, that has at least one-half of the maximum beam power) can be very large and heavy, so hull-mounting is the only practical approach for using these systems. Their drawbacks include installation/removal of transducers requires drydocking the vessel from the water; transducer position is difficult to alter post-installation so bubbles, turbulent boundary layer sweepdown and other noise sources can be difficult to fix, and hull-mounted systems (especially on larger vessels) are located at depths of 5–10 m below the sea surface so the “blind zone” of these installations can be quite large. Most manufacturers provide instructions and recommendations for hull-mounting their systems, but even when these are followed challenges may be encountered.
- Pole-mounted systems can provide flexibility in that transducers can be used from different platforms. However, the engineering design of the pole can be challenging depending on the number and size of transducers, the sea-conditions expected, and the ship being used. Attachment points to decks, gunwales, or other fixed structures on the ship are necessary and raising and lowering the pole-mount system can require the use of cranes or winches. There may be speed limitations to how fast surveys can be done due to mechanical limitations of the pole-mount. A key advantage of pole-mount

systems is that the transducers can be placed closer to the sea-surface reducing the “blind zone” of the system.

- Towfish deployments are advantageous when there are no suitable structures for mounting a fixed pole-mount system or there is a need for near-surface measurements. Towfish systems can be deployed quite close to the sea-surface, however there are challenges in designing a towfish that flies straight and at constant depth, maintains distance from the vessel during ship movements and turns; and in running the mechanical and electrical connections between the towfish, the transducers, the echo sounders, and the ship without putting strain or wear on power and data cables.

### 5.2.2. ADEON Shipboard Acoustic Systems

This project used a combination of Simrad EK60 and EK80 echo sounders (depending on which ship performed the bottom lander service cruises) operating with split-beam transducers at multiple frequencies including: 18, 38, 70, 120, and 200 kHz. These frequencies were chosen for historical reasons since sonar companies only built transducers at specific frequencies and a trade-off in detecting deep fishes using lower frequencies that propagate further versus smaller organisms that scatter energy better at higher frequencies.

These systems received a GPS input from the survey vessel and (when available) attitude/directional information. Multiple frequencies of transducers were connected to a single computer for data acquisition. A second computer, connected to the data acquisition computer via Ethernet, was used for real-time data processing and verification.

Normal operation of these systems is in narrow bandwidth (bandwidth <10 % of center frequency) mode (i.e., traditional EK60 system). However, for some portions of the acoustic survey track, when EK80 systems are available, we will operate them in broadband (bandwidth > 10 % of the center frequency) mode. This provides improved vertical resolution and improved target identification, although at the expense of much larger data sets being collected.

Unlike the fixed systems, ship-based echo sounders may have varying ping rates (due to changes in water depth), but typically will operate with a ping interval between 0.5 to 5 seconds. Pulse lengths vary depending on the operating frequency of the transducer (lower frequencies usually have longer pulse lengths) and the vertical resolution needed in the water column (shorter pulse lengths provide finer vertical resolution), but typical values are 0.128 ms to 4 ms. Power settings are usually set at the maximum value provided by the manufacturer but can be lowered by the user when in shallow water.

Specific details on the data collection and processing done by the [EK60](#) and [EK80](#) systems can be found in the users guides to these systems provided by the manufacturer.



## 6. Acronyms

AAR	anti-aliasing filter
AC	alternating current
ADC	analog to digital converter
ADEON	Atlantic Deepwater Ecosystem Observatory Network
AMAR	Autonomous Multichannel Acoustic Recorder
CHL-a	chlorophyll-a
CMRR	common mode rejection ratio
CSAC	chip-scale atomic clock
CTA	compact towed array
DR	dynamic range
ENOB	effective number of bits
ESA	Endangered Species Act
FFT	fast Fourier transform
FS	full scale
FTP	file transfer protocol
IEEE	Institute of Electrical and Electronics Engineers
IEV	International Electrotechnical Vocabulary
IFREMER	Institut français de recherche pour l'exploitation de la mer
ISO	International Organization for Standardization
LPA TARR	low power array towed array receiver/recorder
MMPA	Marine Mammal Protection Act
MSFD	Marine Strategy Framework Directive (European Union)
NOAA	National Oceanic and Atmospheric Administration
OCS	Outer Continental Shelf
PSRR	power supply rejection ratio
RF	radio frequency
rms	root mean square
SD	secure digital
SFA	Sustainable Fisheries Act
SFDR	spurious free dynamic range
SiNAD	signal to noise and distortion
SNPR	signal to noise power ratio
SNR	signal to noise ratio
SPL	sound pressure level
SST	sea surface temperature



STBD	short-time bearing distribution
TA	towed array
TARR	towed array receiver/recorder
TCXO	temperature controlled crystal oscillator
THD	total harmonic distortion
UNH	University of New Hampshire
UNOLS	University-National Oceanographic Laboratory System
USN	United States Navy

## Literature Cited

- [ISO] International Organization for Standardization. 2017. *ISO 18405.2:2017. Underwater acoustics— Terminology*. Geneva. <https://www.iso.org/obp/ui/#iso:std:iso:18405:ed-1:v1:en>.
- Ainslie, M.A., C.A.F. de Jong, B. Martin, J.L. Miksis-Olds, J.D. Warren, and K.D. Heaney. 2017. *Project Dictionary (Terminology Standard)*. DRAFT. Technical report by TNO for ADEON Prime Contract No. M16PC00003.
- Ainslie, M.A., J.L. Miksis-Olds, B. Martin, K. Heaney, C.A.F. de Jong, A.M. von Benda-Beckmann, and A.P. Lyons. 2018. *ADEON Underwater Soundscape and Modeling Metadata Standard*. Version 1.0. Technical report by JASCO Applied Sciences for ADEON Prime Contract No. M16PC00003.
- David, P.M. 1965. The neuston net A device for sampling the surface fauna of the ocean. *Journal of the Marine Biological Association of the United Kingdom* 45(2): 313-320.
- Devereux, R.F. and R.C. Winsett. 1953. *Isaacs-Kidd Midwater Trawl*. Document Number SIO-Ref-53-3. SCRIPPS Institution of Oceanography, La Jolla, CA.
- Engineers, I.I.o.E.a.E. STD-1057-2007. *IEEE Standard for Digitizing Waveform Recorders*. <https://standards.ieee.org/findstds/standard/1057-2007.html>.
- Engineers, I.I.o.E.a.E. STD-1241-2010. *IEEE Standard for Terminology and Test Methods for Analog-to-Digital Converters*. <https://doi.org/10.1109/IEEESTD.2011.5692956>.
- Harris, R., P. Wiebe, J. Lenz, H.-R. Skjoldal, and M. Huntley. 2000. *ICES Zooplankton Methodology Manual*. 1st edition. Academic Press.
- Lemon, D., P. Johnston, J. Buermans, E. Loos, G. Borstad, and L. Brown. 2012. Multiple-frequency moored sonar for continuous observations of zooplankton and fish. *2012 Oceans*. Oct 14-19. IEEE, Hampton Roads, VA. pp 1-6.
- Method, R.D. 1986. Frame trawl for sampling pelagic juvenile fish. *CalCOFI Rep* 27: 267-278.
- Robinson, S.P., P.A. Lepper, and R.A. Hazelwood. 2014. Good Practice Guide for Underwater Noise Measurement. In National Measurement Office, Marine Scotland, and The Crown Estate (eds.). *NPL Good Practice Guide No. 133*. National Physical Laboratory. p. 97.
- Sousa-Lima, R.S., T.F. Norris, J.N. Oswald, and D.P. Fernandes. 2013. A review and inventory of fixed autonomous recorders for passive acoustic monitoring of marine mammals. *Aquatic Mammals* 39(1): 23-53. [http://mnhk.pnnl.gov/sites/default/files/publications/Sousa\\_Lime\\_et\\_al\\_2013.pdf](http://mnhk.pnnl.gov/sites/default/files/publications/Sousa_Lime_et_al_2013.pdf).
- Texas Instruments. 2011. *A Glossary of Analog-to-Digital Specifications and Performance Characteristics*. TI Application Report SBAA147A. Originally published August 2006. Revised October 2011.
- Urazghildiiev, I.R. and D.E. Hannay. 2018. Passive acoustic detection and estimation of the number of sources using compact arrays. *Journal of the Acoustical Society of America* 143(5): 2825-2833. <https://doi.org/10.1121/1.5037361>.
- Warren, J., J. Miksis-Olds, K. Heaney, C. Lawrence, B. Lucca, H. Blair, H. Kates, Varghese, S. Milea, et al. 2018a. *RV Neil Armstrong, Cruise #25 Report, ADEON Deployment 19 Nov – 15 Dec 2018, Woods Hole, MA to Woods Hole, MA*. 30 pp. <https://adeon.unh.edu/sites/default/files/user-uploads/Post-AR25.Cruise.Report.pdf>.

Warren, J.D., M.A. Ainslie, J.L. Miksis-Olds, B. Martin, and K.D. Heaney. 2018b. *ADEON Calibration and Deployment Good Practice Guide*. Version 1.0. Technical report by Stony Brook University for ADEON Prime Contract No. M16PC00003.

Wiebe, P.H. and M.C. Benfield. 2003. From the Hensen net toward four-dimensional biological oceanography. *Progress in Oceanography* 56(1): 7-136.

## Appendix A. Calculating Sound Levels from Acoustic Recordings

### A.1. Converting Digital Values to Acoustic Pressure

To convert the digital values in the WAV files to acoustic pressure units, the following shall be accounted for:

- The analog-to-digital converter sensitivity to voltage ( $M_{ADC}$ ) of the ADC, which depends on the bit depth  $N_{bit}$  (=16 bit or 24 bit):
  - $M_{ADC} = 1/2^{N_{bit}}$ .
  - Unit: 1.
- Voltage range of the ADC ( $V_{ADC}$ ):
  - $V_{ADC} = V_{max} - V_{min}$  where  $V_{min}$  is the minimum voltage the ADC can convert, and  $V_{max}$  is the maximum voltage the ADC can convert.
  - Unit: volt (V).
- Gain of the hydrophone preamplifiers is  $G$ .
  - Unit: volt per volt (V/V).
- Free-field voltage sensitivity of the hydrophone is  $M_V$ .
  - Unit: volt per pascal (V/Pa).
  - Free-field voltage sensitivity is often expressed in units of V/ $\mu$ Pa because the reference sound pressure in underwater acoustics is 1  $\mu$ Pa.

The preamplifier gain  $G$  is an amplification applied to the hydrophone signal before the ADC. This gain is the ratio of the output voltage to the input voltage:  $G = V_{out}/V_{in}$ , where  $V_{in}$  is the input voltage to the amplifier from the hydrophone and  $V_{out}$  is the output voltage from the amplifier.

A hydrophone converts acoustic pressure to voltage. The free field hydrophone sensitivity level (sensitivity level),  $M_{V,dB}$ , is related to the free field voltage sensitivity (usually expressed in V/Pa or V/ $\mu$ Pa),  $M_V$ , by:

$$M_{V,dB} = 10 \log_{10} \frac{M_V^2}{1 \text{ V}^2/\mu\text{Pa}^2} \text{ dB} .$$

The hydrophone sensitivity is the ratio of the output voltage to the input acoustic pressure. The sensitivity is customarily given as a level (relative to 1 V/ $\mu$ Pa), in decibels, which usually results in a negative value. The sensitivity depends on frequency, but it is usually approximately constant over a nominal bandwidth. A single value of sensitivity level (e.g., -165 dB re 1 V<sup>2</sup>/ $\mu$ Pa<sup>2</sup>) that can be applied to the hydrophone time series is usually provided by the manufacturer based on factory calibration.

For example, for a sensitivity level of  $M_{V,dB} = -165$  dB re 1 V<sup>2</sup>/ $\mu$ Pa<sup>2</sup>, the sensitivity is:

$$M_V = 10^{M_{V,dB}/(10 \text{ dB})} \text{V}/\mu\text{Pa} = 5.623 \cdot 10^{-9} \text{ V}/\mu\text{Pa} .$$

A less negative sensitivity level corresponds to a more sensitive hydrophone. For example, a hydrophone with a sensitivity level of -165 dB re 1 V<sup>2</sup>/ $\mu$ Pa<sup>2</sup> is more sensitive than one with -180 dB re 1 V<sup>2</sup>/ $\mu$ Pa<sup>2</sup>.

The parameters above may be combined into a total sensitivity value:

$$M_{tot} = \frac{1}{V_{ADC}} \cdot M_{ADC} \cdot M_V \cdot G .$$

For example, for a 24-bit channel with an ADC input range of  $\pm 2.5$  V, a gain ( $G$ ) of 2 V/V, and a hydrophone sensitivity level of  $-165$  dB re  $1 \text{ V}^2/\mu\text{Pa}^2$ ,  $M_{\text{tot}}$  is:

$$M_{\text{tot}} = \frac{1}{5 \text{ V}} \cdot 2^{24} \cdot 5.623 \times 10^{-9} \frac{\text{V}}{\mu\text{Pa}} \cdot 2 \frac{\text{V}}{\text{V}} = 0.0377 \frac{1}{\mu\text{Pa}}.$$

A digital value from the ADC is converted to sound pressure by dividing by  $M_{\text{tot}}$ . For the example above and an rms ADC digital output of 10 000, the rms sound pressure is 0.265 Pa, which is equivalent to an SPL of 108.4 dB re  $1 \mu\text{Pa}^2$ .

### Frequency response

In the examples above, the hydrophone sensitivity was assumed to be constant for all frequencies, which is generally untrue. The recorder often also has a low-frequency roll off that shall be accounted for, especially if analyzing frequencies below  $\sim 10$  Hz.

The frequency response of the hydrophone and recorder are generally combined into a single gain-vs-frequency response curve. The response is applied in the frequency domain (after a Fourier transform), instead of the fixed value shown in the equations above.

If a frequency calibrated time series is required (e.g., for directional sensors), the gain shall be applied to the complex Fourier transformed data and then the inverse Fourier transform shall be used to return to the time domain. The input time series length shall be doubled with zeros to eliminate circular convolution in the output time series.

## Appendix B. Sample Specification Sheet for Autonomous Recorders

Tables 8 and 9 provide the standardized metrics that should be provided by manufacturers of acoustic recorders that intended for soundscape quantification. The values for the AMAR G4 recorder (Table 8) and M36-V35-100 hydrophones (Table 9) used on ADEON bottom landers are provided as examples. The specifications for the M20 directional sensor, whose purpose is directionality rather than quantifying the sound levels, are similar but not provided.

Table 8. Recorder metrics.

Reporting metric	Unit	Minimum requirement	AMAR G4
Sample rate	kHz	200	512, 256, 128, 64, 32, 16, 8
Output word size (number of bits)	bit	16	24
Sample clock accuracy–standard clock	Parts per million (ppm)	5	2 (better with higher resolution clocks)
Number of channels		1	4
Synchronous sampling between channels in a multichannel recorder	(yes/no)	yes	yes
–3 dB Frequency response of recorder electronics	Hz	10 to 100 000	2 to 200 000
Recorder dynamic range	dB	96	110
Recorder spectral noise floor assuming a –165 dB re 1 V <sup>2</sup> /μPa <sup>2</sup> hydrophone and 16 kHz sample rate (lower is better)	dB re 1 μPa <sup>2</sup> /Hz	35	<15
Storage capacity	TB	1	12
Power draw for 1 channel at maximum sampling rate (does not include hydrophone)	mW		540
Power draw for 1 channel sampling rate of 16 kHz (does not include hydrophone)	mW		340
Power draw for 4 channels at maximum sampling rate (does not include hydrophone)	mW		985
Power supply capacity at 4 °C	W h		61.5 to 2916
Maximum operating depth	m		250 , 6700
Operating temperature range	°C	–5 to 40	–5 to 50
Storage temperature range	°C	–10 to 50	–18 to 55
Recording schedule options (duty cycling, different sample rates, etc.)		Duty cycling with different sample rates	Duty cycle, sample rate, delay start, schedule of schedules
Input gain control			Fixed gain to match hydrophone

Table 9. Standard hydrophone metrics.

Reporting metric	Unit	GTI M36-V35-100
Free-field hydrophone sensitivity level (if including hydrophone in specification)	dB re 1 V <sup>2</sup> /μPa <sup>2</sup>	-165
Hydrophone frequency passband (lower and upper frequencies that are 3 dB below the average free-field hydrophone sensitivity level)	Hz	17 to 180 000
Maximum operating depth	m	2500
Hydrophone spectral noise floor level	dB re 1 μPa <sup>2</sup> /Hz	34



## Appendix C. Specification Sheets for Equipment

### C.1. SBE-37 CT-DO Sensor

The following specification is verbatim from: <http://www.seabird.com/sbe37smpodo-microcat-ctd-do>. Useful conversions are: 1 bar = 100 kPa; 1 dbar = 0.1 bar = 10 kPa.

The SBE 37-SMP-ODO pumped MicroCAT is a high-accuracy conductivity and temperature (pressure optional) recorder with Serial interface (RS-232 or RS-485), internal batteries, Memory, integral Pump, and Optical Dissolved Oxygen. The MicroCAT is designed for moorings or other long-duration, fixed-site deployments.

Data is recorded in memory and can be output in real-time. Measured data and derived variables (salinity, sound velocity, specific conductivity) are output in engineering units.

Memory capacity exceeds 380,000 samples. Battery endurance varies, depending on sampling scheme and deployment temperature and pressure. Sampling every 15 minutes (10 °C, 500 dbar), the MicroCAT can be deployed for almost 9 months (25,000 samples).

#### Features

- Moored Conductivity, Temperature, Pressure (optional), and Optical Dissolved Oxygen, at user-programmable 10-sec to 6-hour intervals.
- Integral pump.
- RS-232 or RS-485 interface.
- Internal memory and battery pack (can be powered externally).
- Expendable anti-foulant devices, unique flow path, and pumping regimen for bio-fouling protection.
- Adaptive Pump Control for high-accuracy oxygen data.
- 7000 m titanium housing.
- [Seasoft®V2](#) Windows software package (setup, data upload, and data processing).
- Field-proven MicroCAT family, with more than 10,000 instruments deployed.
- Five-year limited [warranty](#).

#### Components

- Unique internal-field conductivity cell permits use of expendable anti-foulant devices, for long-term bio-fouling protection.
- Aged and pressure-protected thermistor has a long history of exceptional accuracy and stability.
- Oxygen sensor is field-proven, individually calibrated [SBE 63 Optical Dissolved Oxygen sensor](#)
- Pump runs for each sample, providing improved conductivity and oxygen response, bio-fouling protection, and correlation of CTD and oxygen measurements.

#### Options

- Titanium (7000 m) housing.
- RS-232 interface.
- Wet-pluggable MCBH connector.

## C.2. VEMCO VR2-W Fish Tag Logger

The following specification is verbatim from: <https://vemco.com/products/vr2w-69khz/?product-specifications>.

[« BACK TO PRODUCT LIST](#)

# VR2W – 69 kHz

RECEIVERS

Overview

**Specifications**

Software & Manuals

FAQs

Tutorials & Tools

Sample Studies

SHARE



### Specifications

Dimensions	308 mm long x 73 mm diameter
Weight	1190 g in air, 50 g in water
Power supply	1 – 3.6 V Lithium D cell battery
Battery life	Approximately 15 months
Maximum depth	500 metres
Receive frequency	69 kHz standard
Storage	Approximately 1.6-million detections (16 MBytes non-volatile flash memory) Approximately 1-million detections (8 MBytes non-volatile flash memory)
Attachment	Standard: cable ties
Firmware	Field upgradable receiver firmware
Software	VEMCO user Environment (VUE) software
Transmitters	Logs and decodes ALL Vemco 69 kHz transmitters
Code maps	Support for all current and planned Vemco code maps